

LOWER RIO GRANDE PUBLIC WATER WORKS AUTHORITY

MINUTES - REGULAR BOARD OF DIRECTORS MEETING

9:00 a.m. Wednesday, March 21, 2012 at the Vado Office, 325 Holguin Road

NOTE: Minutes are a DRAFT until they are approved and signed by the Board of Directors

- I. **Sign in, establish quorum, call meeting to order:** Sign in sheet and agenda are attached. Board members present were Chairman Roberto "Marty" Nieto, Vice-Chairman John Holguin, and Secretary Santos Ruiz. Absent were Directors Rosaura Pargas and Blanca Martinez. Staff members present were General Manager Martin Lopez, Operations Manager Mike Lopez, Projects Manager Karen Nichols, and HR/Payroll Specialist Connie Garcilazo. Also present were Espie Holguin, Matt Dyer, Marcy Trujillo, and Dean Lucky. With quorum established the meeting was called to order by Mr. Nieto at 9:11am. {:21}
- II. **Approval of agenda:** Mr. Holguin made a motion to approve the agenda, Mr. Ruiz seconded, and the motion carried on a vote of 3-0. {:50}
- III. **Approval of Minutes of 2/15/12:** Mr. Holguin made a motion and Mr. Ruiz seconded to approve the minutes dated 2/15/12 (attached). The motion carried on a vote of 3-0. {3:20}
- IV. **Guest Presentations: Matt Dyer of Parkhill, Smith & Cooper presentation on SCADA and electrical system design relative to water/wastewater applications.** Mr. Dyer Mr. Trujillo and Mr. Lucky gave a presentation (attached) regarding Electrical and SCADA System among other services offered by their company. {40:35}
- V. **Public Input - 15 minutes total allotted for this item, 3 minute time limit per person, may be continued after Item VIII by board action:**
Mr. Lopez presented a letter (attached) from a customer Orlando Jimenez and his concern regarding water service disconnection. Additional disconnect notices and associated cost will be explored and presented next month board meeting. Mr. Lopez also provided copies (attached) of the El Paso Electric Company disconnection procedures from their website. {51:50}
- VI. **General Manager's Reports:**
 - A. **Management Report:** Mr. Martin Lopez's written report was in the board packet (attached) and he presented it to the Board of Directors. {1:02:39}
 - B. **Finance Report:** Ms. Jackson not present due to training. Mr. Lopez informed the board that credit card services should be up and running in the Mesquite and Berino offices and stated that income and expenses for the month of February broke even. {1:03:20}
 - C. **Projects Report:** Ms. Nichols written report was in the board packet (attached) and she reviewed it with the Board. {1:21:38}
 - D. **Operations Report:** Mr. Mike Lopez's written report was in the board packet (attached) and he reviewed with the Board. Mr. Lopez informed the board that the SWAT lab at NMSU which has been handling our microbiological testing will be closing in June and the water samples will be picked up from a lab located in Ruidoso. {1:29:30}

VII. Unfinished Business:

A. Rate Study

- 1. Report on Public Hearing:** A list (attached) of questions and concerns from customers who attended public hearing and responses from Mr. Lopez and Ms. Nichols were included in the board packet. Mr. Lopez reviewed the Powerpoint presentation from the Public Hearing, and Ms. Nichols noted that all deliverables have been received from Medius, Inc., Annette Morales' company which coordinated the hearing. She said that Ms. Morales' son was going to break up the video from the hearing into two or three segments that can be posted on YouTube, and when he gets that done, she will get a link posted on our website or embed the videos if possible. {1:44:40}
- 2. Implementation:** After considering comments from the public, and in order to satisfy the requirements of Rural Development, Mr. Holguin made a motion and Mr. Ruiz seconded to implement water rate increase effective April 1st 2012. Motion carried on a vote of 3-0. {1:49:00}

B. Disposal of old Berino tank

Mr. Lopez informed the Board that two proposals were received and both are for same amount Romero Recycling and Luis Castro. Romero Recycling will additionally pay taxes cost and Insurance information was provided. Mr. Lopez already authorized at previous meeting to make a decision will contact Romero Recycling. {1:52:21}

- C. Election Policy:** Mr. Lopez reviewed the draft policy with the board and informed them that the attorney had already reviewed and revised it. Mr. Ruiz made a motion to adopt the election policy, it was seconded by Mr. Holguin and carried on a vote of 3-0. {1:57:45}

VIII. New Business

- A. Joint Resolution FY2012-01: O&M Interagency Agreement Amendment w/ La Union MDS&WA:** Mr. Ruiz made a motion to extend Operations and Maintenance contract with La Union for one more year, Mr. Holguin seconded the motion and it carried on a vote of 3-0. {2:00:00}

- B. Authorization to apply to Colonias Infrastructure Trust Fund for Mesquite Wastewater Project & Surface Water Treatment Facility Design Project:** Mr. Holguin made a motion to approve submitting applications for Colonias Infrastructure Program Grants for the Mesquite Wastewater Project and the Surface Water Treatment Facility Design Project. Mr. Ruiz seconded motion, and it carried on a vote of 3-0. {2:03:20}

- C. Engineers Tabulation & Recommendation for Bid Award/La Mesa Well Project**
Mr. Holguin made a motion to accept the Engineers Tabulation & Recommendation for Bid Award for the La Mesa Well Project and award the contract to Burn Construction contingent upon USDA Rural Development concurrence. Mr. Ruiz seconded, and the motion carried on a vote of 3-0. {2:06:44}

IX. Other discussion and agenda items for next meeting 4/18/12: Items mentioned for inclusion in the next agenda included seeking a meeting with Governor, approval for attorney to draft an amendment to the personnel policies regarding the handling of complaints against the General Manager, and options and costs of providing additional disconnection notices. {2:06:44}

X. Adjourn

Mr. Holguin made a motion to adjourn the meeting, it was seconded by Mr. Ruiz and carried on a vote of 3-0. Mr. Nieto declared the meeting adjourned at 11:25 a.m.

Date Minutes Approved: _____

LRGPWWA Directors Present:

Chairman, Roberto M. Nieto

Vice- Chairman, John Holguin

Secretary, Santos Ruiz

Absent
Director, Rosaura Pargas

Absent
Director, Blanca Martinez

Lower Rio Grande Public Waterworks Authority Sign In Sheet

Date: 3/21/12 Time: 9am Place: Vado Office Meeting Type: Regular

Name, Title - Print Sign	Company or Agency Represented	Mailing Address	Telephone	Email
<u>LEANN LACHNEY, PE</u>	PSC	115 W. G. RINGS	575-553-0915	wlachney@team-psc.com
<u>Matt Dyer PE</u> <u>or Matt Dyer</u>	PSC	" "	" "	mdyer@team-psc.com
<u>MARCELO TRUJILLO</u> <u>Mechanical Engineer</u> <u>Español Holguin</u>	PSC	" "	575-553-0915	marcelo.trujillo@ps.com
<u>Roberto M. Nieto</u>	LRG	525 Holguin	575-635-1289	
<u>Johany O. Holguin</u>	LRG	615 Holguin	621-9697	jholguin@lg.com
<u>Santia Ruiz</u>	LRG	Bering P O Box 106	575-882-5937	
<u>Connie Garcilazo</u>	LRG/PWWA	PO BOX 2046 -Anthony NM	575-882-5072	connie.garcilazo@ lrgauthority.org
<u>Michael Lopez</u> <u>Michael Lopez</u>	LRG/PWWA	P.O. Box 2046 Anthony NM 88021	(575) 635-3921	mike.lopez@lrg authority.org
<u>Karen Nichols</u>	LRG/PWWA	P.O. Box 2046 Anthony NM 88021	515-203-2057	karen.nichols@ LRG Authority.org
<u>MARTIN G Lopez</u> <u>[Signature]</u>	LRG/PWWA	335 Holguin Rd Vado, NM 88072	575 571-3628	martin.lopez@ lrgauthority.org

LOWER RIO GRANDE PUBLIC WATER WORKS AUTHORITY

MEETING NOTICE & AGENDA - REGULAR BOARD OF DIRECTORS MEETING

9:00 a.m. Wednesday, March 21, 2012 at the Vado Office, 325 Holguin Road

Agendas are final 24 hours prior to the meeting and may be obtained at any LRGPWWA Office – call 575-233-3947 for information

- I. Sign in, establish quorum, call meeting to order
- II. Approval of agenda
- III. Approval of Minutes of 2/15/12
- IV. Guest Presentations: Matt Dyer of Parkhill, Smith & Cooper presentation on SCADA and electrical system design relative to water/wastewater applications
- V. Public Input - 15 minutes total allotted for this item, 3 minute time limit per person, may be continued after Item VIII by board action:
- VI. General Manager's Reports:
 - A. Management Report
 - B. Finance Report
 - C. Projects Report
 - D. Operations Report
- VII. Unfinished Business:
 - A. Rate Study
 1. Report on Public Hearing
 2. Implementation
 - B. Disposal of old Berino tank
 - C. Election Policy
- III. New Business:
 - A. Joint Resolution FY2012-01: O&M Interagency Agreement Amendment w/ La Union MDS&WA
 - B. Authorization to apply to Colonias Infrastructure Trust Fund for Mesquite Wastewater Project & Surface Water Treatment Facility Design Project
 - C. Engineers Tabulation & Recommendation for Bid Award/La Mesa Well Project
- IX. Other discussion and agenda items for next meeting 4/18/12
- X. Adjourn

If you are an individual with a disability who is in need of a reader, amplifier, qualified sign language interpreter, or any other form of auxiliary aide or service to attend or participate in the hearing or meeting, please contact the LRG PWWA office at 575-233-3947, 325 Holguin Rd, Vado NM 88072 at least one week prior to the meeting or as soon as possible. Public documents, including the agenda and minutes, can be provided in various accessible formats. Please contact the LRGPWWA office if a summary or other type of accessible format is needed.

Si es un individuo con una incapacidad esta en necesidad de un lector, amplificador, lenguaje por señas, o cualquier otra forma de asistencia o servicio para atender o participar en las juntas, por favor llame a la oficina LRG PWWA office at 575-233-3947, 325 Holguin Rd, Vado NM 88072 una semana antes de la junta o en cuanto posible. Documentos públicos, incluyendo la agenda y minutos, están disponibles en varios formatos. Por favor opóngase en contacto con la oficina LRGPWWA si un resumen o otro tipo de forma accesible es necesario.

LOWER RIO GRANDE PUBLIC WATER WORKS AUTHORITY

MINUTES - REGULAR BOARD OF DIRECTORS MEETING

9:00 a.m. Wednesday, February 15, 2012 at the Vado Office, 325 Holguin Road

{NOTE: Minutes are a DRAFT until approved and signed by the Board of Directors}

- I. **Sign in, establish quorum, call meeting to order:** Sign in sheet and agenda are attached. Directors present were Chairman Robert “Marty” Nieto, Vice-chairman John Holguin, Secretary Santos Ruiz, Directors Rosaura Pargas and Blanca Martinez. Staff present were General Manager Martin Lopez, Finance Manager Kathi Jackson, Projects Manager Karen Nichols, Operations Manager Mike Lopez, Payroll Specialist Connie Garcilazo and Accounts Payable Specialist Benita Evaro. Also present were LRGPWWA Attorney Beverly Singleman and Espy Holguin. With a quorum established the meeting was called to order by Mr. Nieto at 9:07 am.
- II. **Approval of agenda:** A motion was made by Ms. Pargas and seconded by Ms. Martinez to approve the agenda. The motion carried on a vote of 5-0. {55}
- III. **Approval of Minutes of 11/16/11, 12/7/11, 1/12/12, 1/19/12, 2/1/12 (all attached):** Ms. Martinez made a motion to approve the minutes dated 11/16/11, Mr. Ruiz seconded, and it carried on a vote of 3-0 (Directors present at that meeting). A motion was made by Mr. Holguin and seconded by Mr. Ruiz to approve the minutes dated 12/7/11, and the motion carried on a vote of 4-0 (Directors present at that meeting). Mr. Holguin made a motion to approve the minutes dated 01/12/12, Mr. Ruiz seconded, and the motion carried on a vote of 4-0. Mr. Holguin made a motion to approve the minutes dated 1/19/12 with one correction on last sentence of item I to delete “RN called to order”. The motion was seconded by Mr. Ruiz and carried on a vote of 5-0. A motion was made by Ms. Pargas to approve the minutes dated 2/1/12, seconded by Ms. Martinez, and carried on a vote of 5-0. {10:15}
- IV. **Guest Presentations:** None
- V. **Public Input - 15 minutes total allotted for this item, 3 minute time limit per person, may be continued after Item VIII by board action:** None
- VI. **General Manager’s Reports:**
 - A. **Management Report:** Mr. Martin Lopez written report was in the board packet (attached), and he reviewed it with the Board. {14:42}
 - B. **Finance Report:** Ms. Jackson handed out and reviewed her written report (attached) with the Board. Ms Jackson stated that she is working on creating a policy for accounts with past due balances for a period of six months or more. {23:46}
 - C. **Projects Report:** Ms. Nichol’s written report was in the board packet (attached) and she reviewed report with the board. {42:34}
 - D. **Operations Report:** Mr. Mike Lopez informed the board that he had no written report this month because he has been tied up with problems with the well at Desert Aire MDWCA. He stated that there are no major problems with any of the other systems. {50:15}
- VII. **Unfinished Business:**
 - A. **Rate Study – delay implementation to 4/1/12 to allow time for public hearing:** Mr. Lopez (GM) reported that he had the Projects Manager issue an informal request for bids for conducting the required public hearing, and the project was awarded to Medius, Inc. as a small purchase authorized by him. The full report from that hearing will be presented to Board at the March meeting, and implementation of the new rates will need to be delayed until then. {55:44}

VIII. New Business:

- A. Resolution FY2012 AUTHORIZING AND APPROVING SUBMISSION OF A COMPLETED APPLICATION FOR FINANCIAL ASSISTANCE AND PROJECT APPROVAL TO THE NEW MEXICO FINANCE AUTHORITY (DWSRLF Funds for Radio Read Meters):** Ms. Nichols explained that this projected had been initiated by Mr. Lopez (GM) with a Project Interest Form even before our merger. We were finally notified that the project was approved for \$595,000 funding that will be 25% grant, 25% subsidized loan (aka grant) and 50% 20 year loan at 0%, and she is now completing the application form which requires the Certification and the Resolution provided in the board packet (attached). A motion was made by Mr. Holguin to adopt Resolution FY 2012, seconded by Mr. Ruiz, and carried on a vote of 5-0. {58:50}
- B. Noise Policy:** Ms. Singleman discussed her suggestion for developing a noise policy. She said that it was not something that the attorney needed to write. There was a lengthy discussion concerning the need for a noise policy with Ms. Jackson and Ms. Evaro stating their opinions that it was unnecessary. Mr. Nieto and Mr. Holguin stated their opinion that the policy is necessary. A motion was made by Ms. Pargas to authorize Mr. Lopez (GM) develop a policy regarding noise in the workplace and present it to the board for approval. Ms. Martinez seconded the motion, and it carried on a vote of 5-0. {1:19:35}
- C. Creation of a policy to address Authority business in the absence of the GM, inclusive of handling of grievances and investigation against GM by the Attorney:** A motion was made by Mr. Holguin and seconded by Mr. Ruiz to expand personnel policy on grievances to be written by Ms. Singleman to address how grievances against the General Manger will be handled.. Motion carried on a vote of 5-0. Mr. Lopez (GM) also pointed out that he needs some closure on the last grievance against him. Ms. Singleman said she would wrap it up within the next week and will present to the Board at the next special or regular meeting. Consensus of the board was to handle it at the next regular meeting. {1:29:13}
- D. Mesquite WW Project – Bid award contingent on USDA-RD concurrence:** Mr. Lopez discussed the Bid Tabulation showing Reynolds Southwest, Inc. as low bidder. He explained that there is not enough money to complete the entire project and proposed to approach Colonias Trust Board for funding. He noted that RD funding will cover bid lots 1-7 of 10 with adequate contingencies, and that staff and the engineer are meeting with county engineering staff to see if it will be possible to get a waiver from some of the paving requirements to reduce costs enough to perhaps add bid lot 8. Mr. Holguin made a motion to approve the award contingent on USDA Rural Development Concurrence and Mr. Ruiz seconded, motion carried on a vote of 5-0 {1:36:13}
- E. Disposal of unused water tanks:** Mr. Lopez (GM) and Mr. Lopez (OM) discussed the locations and reasons that a few water storage tanks are not being used. Ms. Pargas made a motion to authorize the General Manager to explore the disposal of unused water tanks. Ms. Martinez seconded the motion, and it carried on a vote of 5-0. {1:40:15}
- F. O&M Contract with Butterfield Park MDWCA – for approval:** Mr. Lopez (GM) discussed the request from Butterfield Park MDWCA for an O&M contract for two months with an option to renew. Mr. Holguin made a motion to approve the Operation & Maintenance Contract with Butterfield Park MDWCA. Mr. Ruiz seconded motion and it carried on a vote of 5-0. {1:45:45}
- G. Request to DAC for transfer of ownership of the Mesquite Recreation Center:** Mr. Lopez reminded the board that he had reported to them several months ago about a conversation he had with county Parks & Recreation staff asking if we would consider taking ownership of the Mesquite Recreation Center. He said that a follow-up conversation occurred recently, and we

were asked to submit a letter requesting the transfer of ownership. A motion was made by Mr. Holguin to authorize the General Manager to submit a letter to Dona Ana County requesting transfer of ownership of the Mesquite Recreation Center to the LRGPWVA. Ms. Pargas seconded the motion, and, following some discussion, it carried on a vote of 5-0. {1:51:55}

H. Merger Procedures – for approval: Mr. Lopez explained that he and Ms. Nichols had brainstormed this procedure in response to a couple of requests from mutual domestic associations, and Ms. Nichols said that she had some written edits from Ms. Singleman to incorporate. Ms. Singleman said that her edits were not substantial, but just language clarification that should not delay board approval. After some discussion, Ms. Martinez made a motion to approve the proposed merger procedures for Mutual Domestic Associations to Merge with Lower Rio Grande PWVA. The motion was seconded by Mr. Holguin and carried on a vote of 5-0. {2:00:25}

IX. Other discussion and agenda items for next meeting 3/21/12: Items for next month meeting include La Union O & M Contract expiration, resolution of grievance against the General Manager. Next meeting is scheduled for 03/21/12 at 9:00 a.m. at the Vado Office. {2:17:10}

X. Adjourn: Mr. Holguin made a motion to adjourn the meeting, Mr. Ruiz seconded, and it carried on a vote of 5-0. Mr. Nieto declared the meeting adjourned at 11:23 a.m.

Date Minutes Approved: _____

Directors Present:

Chairman Roberto M. Nieto

Vice- Chairman John Holguin

Secretary Santos Ruiz

Director Rosaura Pargas

Director Blanca Martinez



PARKHILL **SMITH** & COOPER



ELECTRICAL AND SCADA ENGINEERING SERVICES

Some Background

- Six Electrical PEs and One Controls PE.
- A support staff of over 200
- Electrical RPRs
- Extensive Portfolio of Water and Wastewater Projects



Services We Provide

- Power Distribution



Services We Provide

- Power Distribution
- Short Circuit Analysis

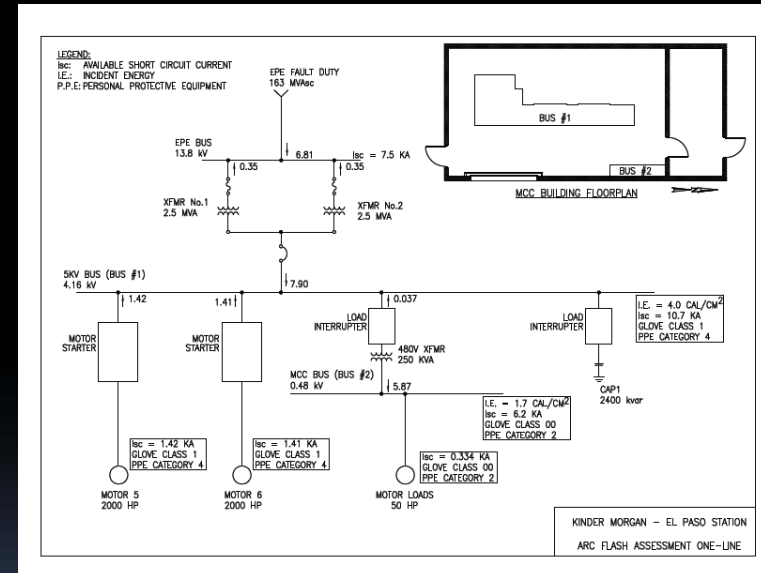

Services We Provide

- Power Distribution
- Short Circuit Analysis
- Coordination Studies

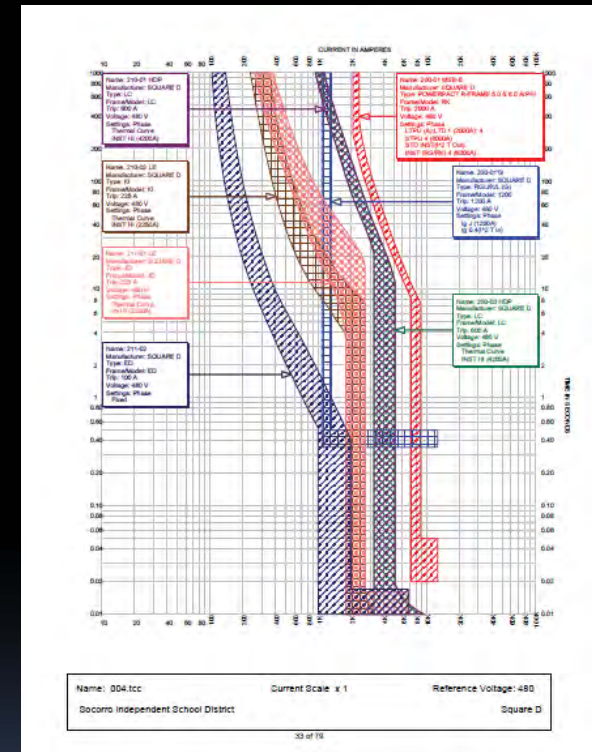

Services We Provide

- Power Distribution
- Short Circuit Analysis
- Coordination Studies
- Voltage Drop Calculations



Services We Provide

- Power Distribution
- Short Circuit Analysis
- Coordination Studies
- Voltage Drop Calculations
- Arc Flash Studies

 WARNING	
Arc Flash and Shock Hazard Appropriate PPE Required	
24 inch	Flash Hazard Boundary
3	cal/cm ² Flash Hazard at 18 inches
1	PPE Level, 1 Layer 6 oz. Nomex, Leather Gloves Faceshield
480 VAC	Shock Hazard when Cover is removed
42 inch	Limited Approach
12 inch	Restricted Approach - 500 V Class 00 Gloves
1 inch	Prohibited Approach - 500 V Class 00 Gloves
Equipment Name: MIDWEST	



Services We Provide

- Power Distribution
- Short Circuit Analysis
- Coordination Studies
- Voltage Drop Calculations
- Arc Flash Studies
- Grounding Design



Services We Provide

- Power Distribution
- Short Circuit Analysis
- Coordination Studies
- Voltage Drop Calculation
- Arc Flash Studies
- Grounding Design
- Lighting Design



Services We Provide

- Generator Sizing



Services We Provide

- Generator Sizing
- Lightning Protection



Services We Provide

- Generator Sizing
- Lightning Protection
- Utility Relocation



Services We Provide

- Generator Sizing
- Lightning Protection
- Utility Relocation
- Building Inspections



Services We Provide

- Generator Sizing
- Lightning Protection
- Utility Relocation
- Building Inspections
- Data Comm. Centers



Services We Provide

- Generator Sizing
- Lightning Protection
- Utility Relocation
- Building Inspections
- Data Comm. Centers
- DC Power Distribution



Services We Provide

- Generator Sizing
- Lightning Protection
- Utility Relocation
- Building Inspections
- Data Comm. Centers
- DC Power Distribution
- Energy Efficiency Strategies



Solar Panel Payback Calcs

- Off the Grid or On the Grid
- Installation Cost
- Power Produced By a Solar Panel System
- System Load
- Incentives
 - Net metering
 - Renewable Energy Certificates
- Cost of Electricity



VFD Install Evaluation



Power Consumption (in %
incl motor & system
losses)

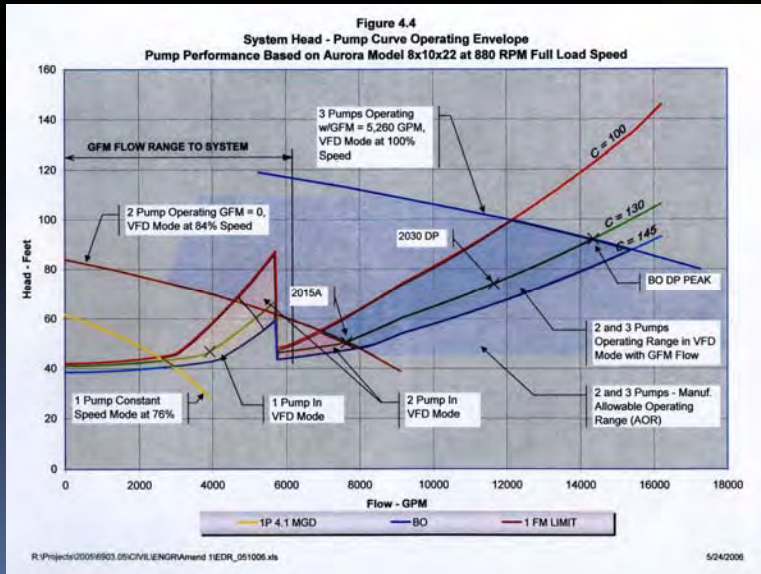

SCADA

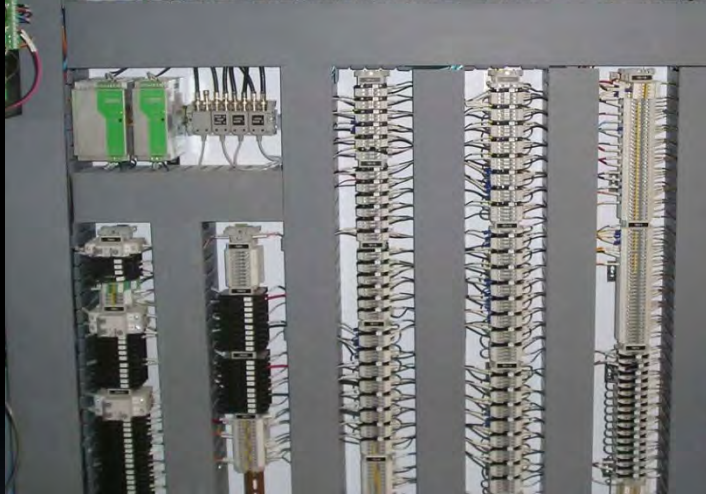

SCADA

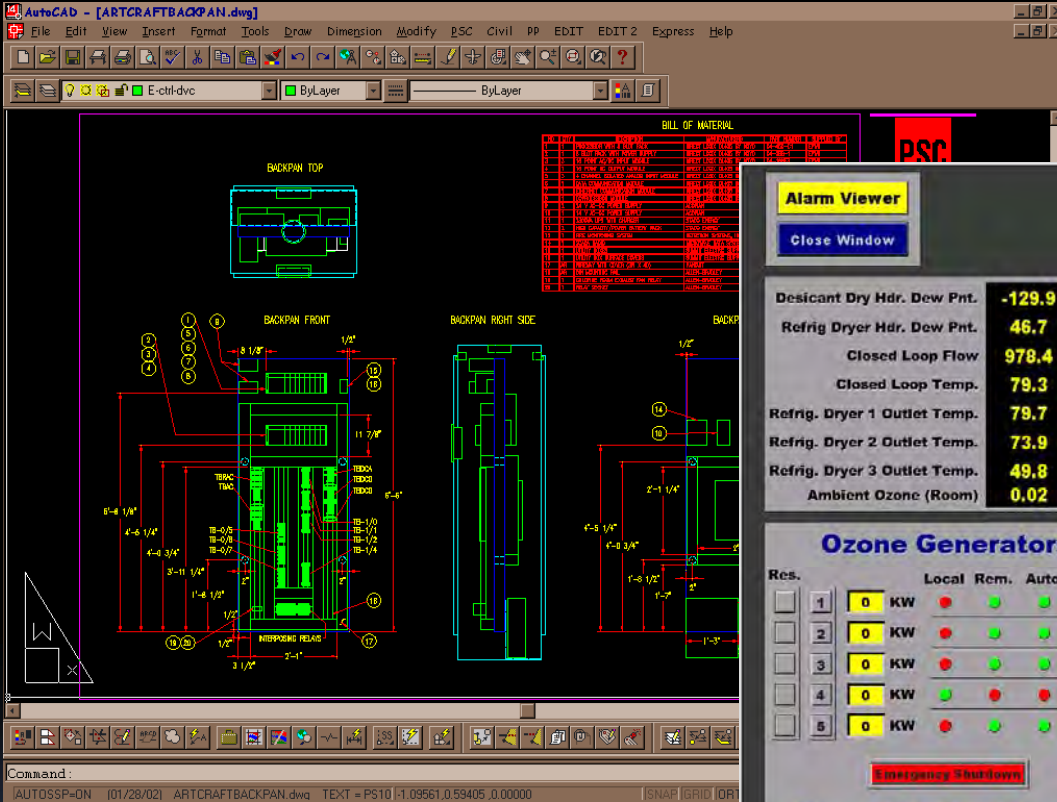

Alarm Viewer

Close Window

Desiccant Dry Hdr. Dew Pnt.	-129.9	°F
Refrig Dryer Hdr. Dew Pnt.	46.7	°F
Closed Loop Flow	978.4	GPM
Closed Loop Temp.	79.3	°F
Refrig. Dryer 1 Outlet Temp.	79.7	°F
Refrig. Dryer 2 Outlet Temp.	73.9	°F
Refrig. Dryer 3 Outlet Temp.	49.8	°F
Ambient Ozonc (Room)	0.02	%

Ozone Generators

Res.	Local	Rem.	Auto	Man.
1	0 KW	●	●	●
2	0 KW	●	●	●
3	0 KW	●	●	●
4	0 KW	●	●	●
5	0 KW	●	●	●
6	0 KW	●	●	●

Emergency Shutdown

Ozone Cooling Pumps

Raw Water Pumps	Closed Loop Pumps
1	1
2	2
3	3
	4

Unit	Flow	Temp	Power
1	0.00 %	80.1 °F	0.00 KW
2	78.9 °F	376.0 SCFM	0.0 KW
3	0.3 SCFM	81.0 °F	0.0 SCFM
4	0.0 KW	0.0 SCFM	0.0 KW
5	1.25 %	40.0 °F	0.0 SCFM
6	118.7 °F	0.0 SCFM	0.0 KW
7	360.1 SCFM		
8	244.5 KW		



Hydraulic/Pneumatic Controls



Performance Spec / Black Box

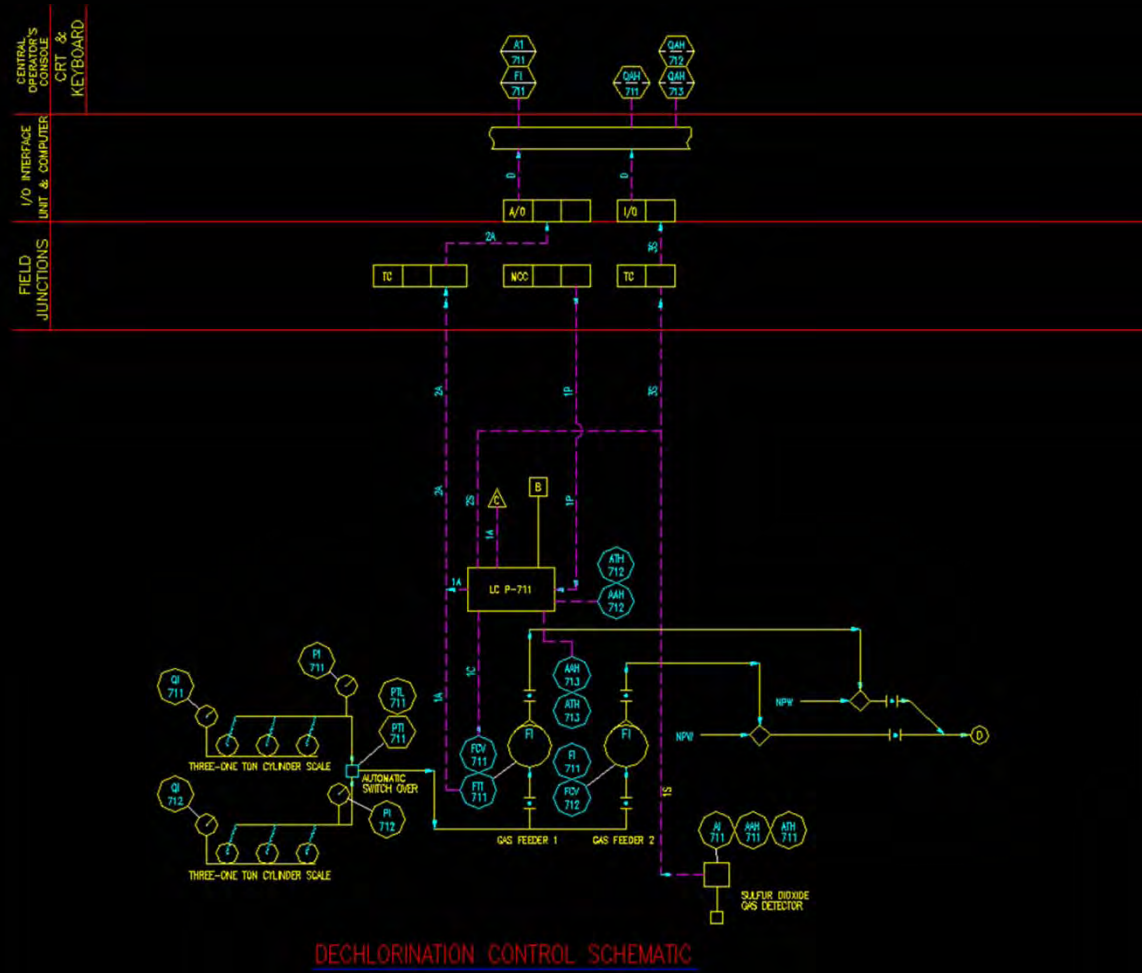

Performance Spec / Black Box

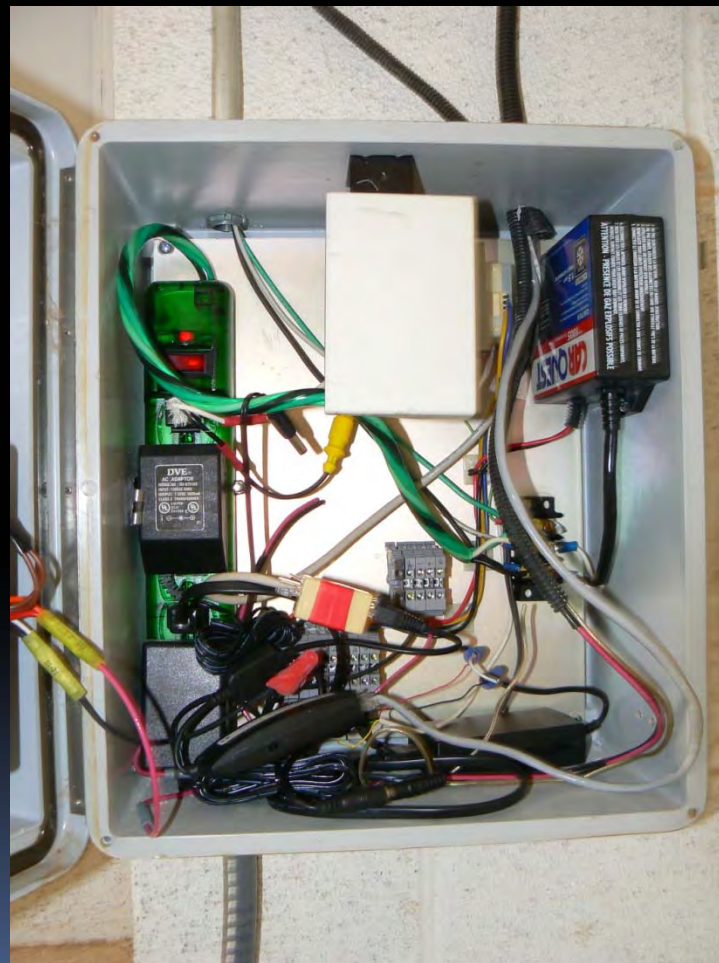

Performance Spec / Black Box

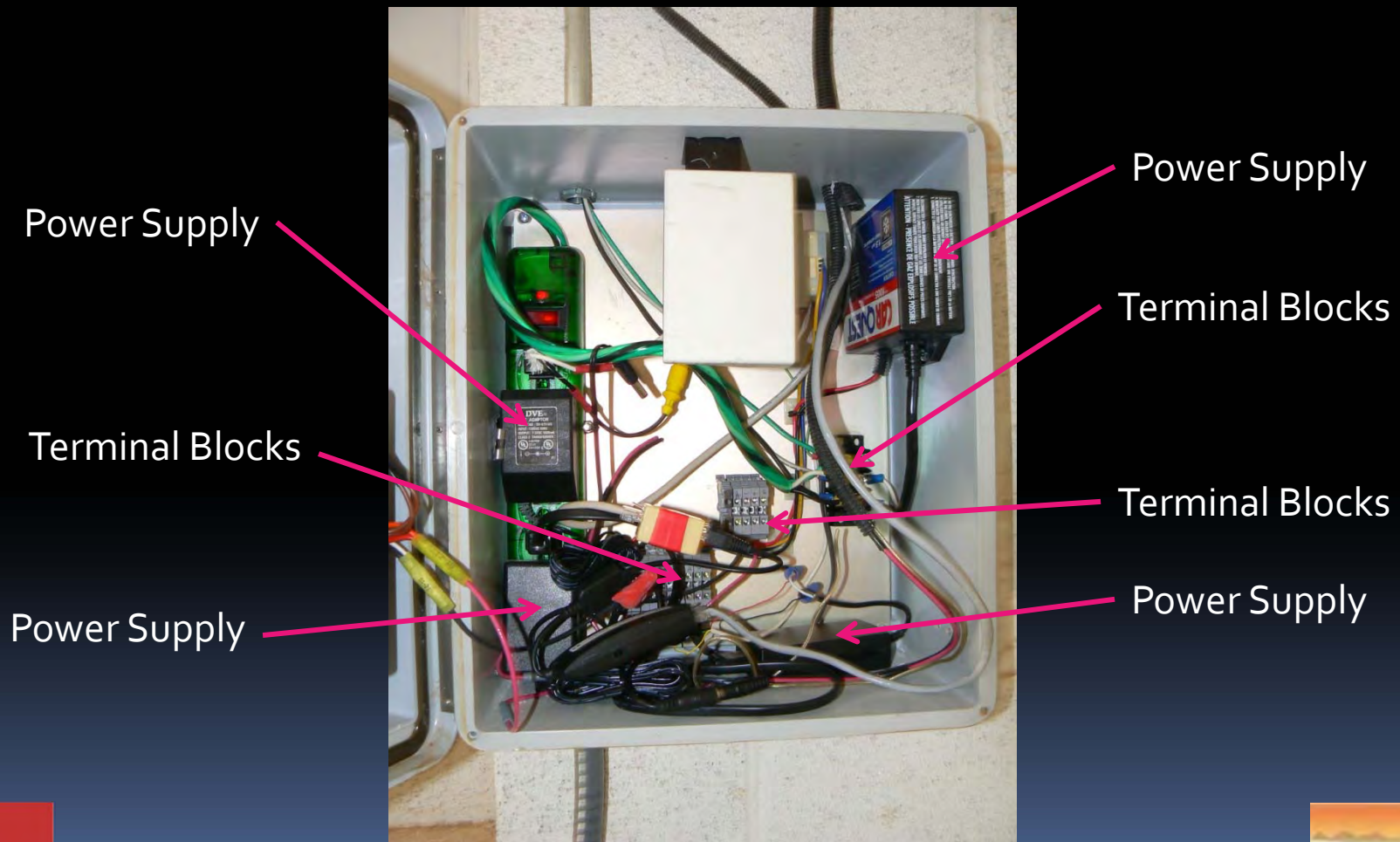

Complete SCADA Design

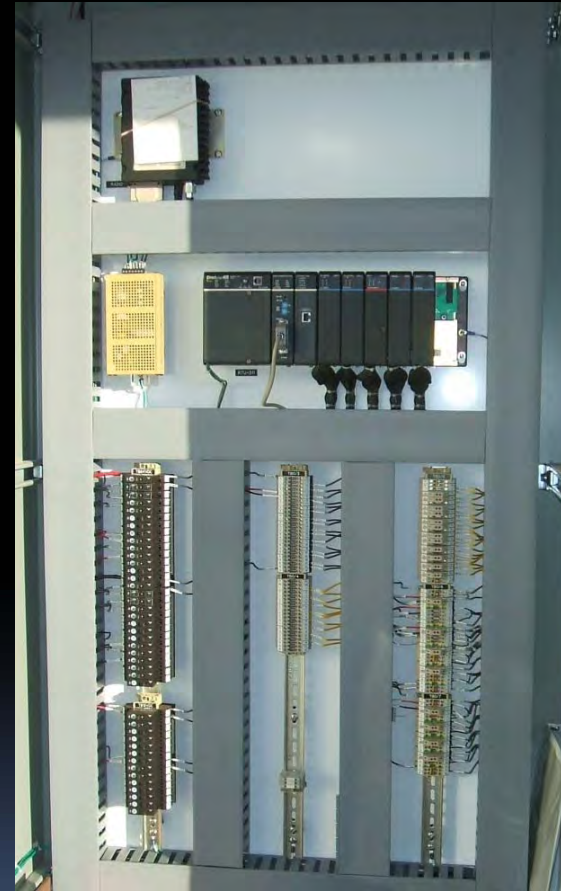
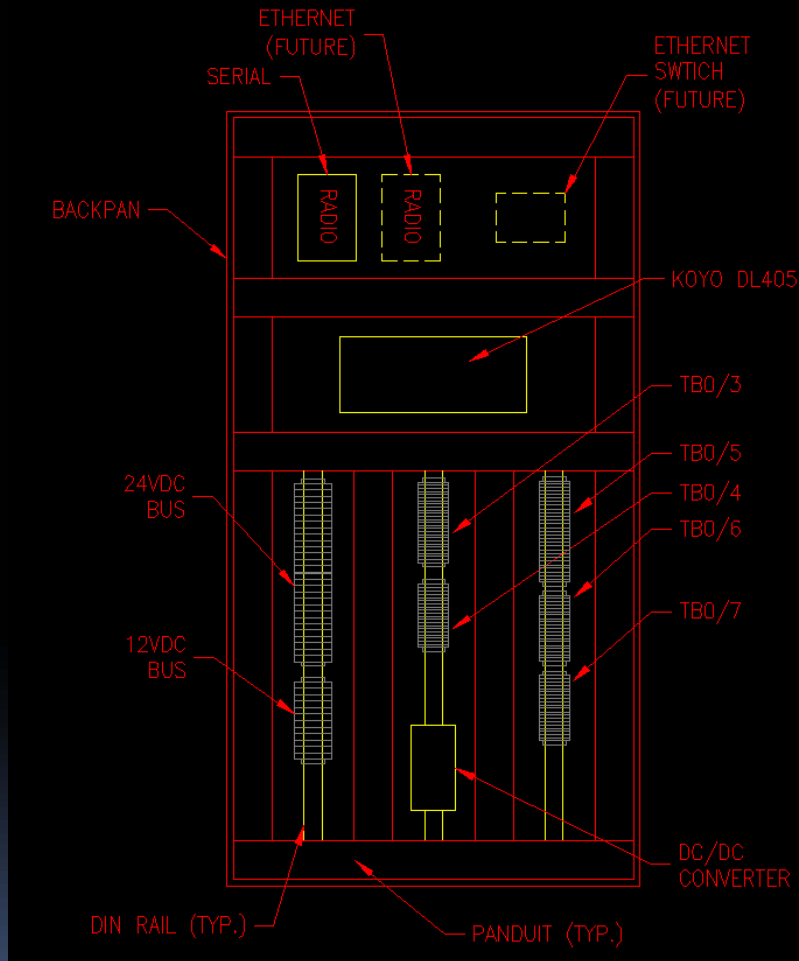

Radio Path Analysis

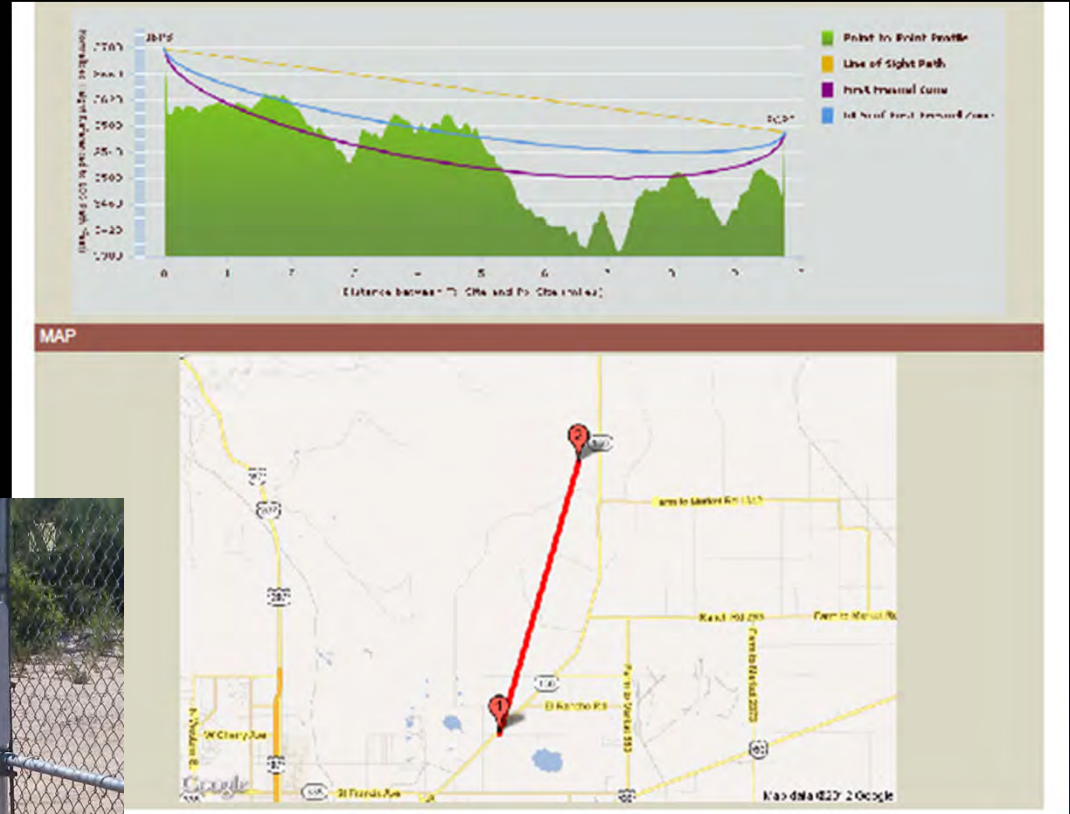

Field Devices



Site Security



Electrical and SCADA Engineering Services

- Short Circuit Study
- Coordination Study
- Voltage Drop Calculations
- Power Distribution
- Grounding Design
- Arc Flash Study
- Lighting Design
- Generator Sizing
- Lightning Protection
- Radio Path Analysis
- Solar Panel Payback
- VFD Install Evaluation
- Energy Efficiency Strategies
- Utility Relocation
- DC Power Distribution
- SCADA
- Hydraulic Controls
- Data Communication Centers
- Building Inspections
- Site Security



**LRG PWWA
Manager's Report
March 21, 2012**

- Transfer of Assets from Associations
 - Lack the USDA construction accounts for the Mesquite water project-need project as-builts from Smithco; O&M Manual from Gannett
- Authority-Brazito projects: emergency water interconnection: pending funding on LRGPWWA side and on Brazito side they have opened bids
- Authority-Alto de Flores (emergency water interconnection) pending funding, advertisement for supplement well next 3 Fridays in LC Bulletin
- Will begin FY13 Budget preparation within the next couple of weeks
- Will begin Noise Policy-gathering a team of employees to draft
- Desert Aire has requested a proposal to operate all aspects of their operations and will at their April meeting take a vote to approach membership about joining LRGPWWA
- Butterfield Park and Organ will be having information meetings about joining LRGPWWA on April 24th and May 2nd at Butterfield Park Community Center
- Butterfield Park additionally will probably request an extension to O&M Contract (Operator applicants are not suitable of the 3 they have received)
- Meetings/Trainings

- County P&Z Reaffirm Colonias Designation
March 22 at 9 at County
- R-Cubed Dairy Discharge treatment
presentation at DACC Anthony at 6:30 pm
- NM Water Trust Board presentation March 28
in Santa Fe
- La Mesa Building, April 6 at 1 am at job site
- DAC BOCC Reaffirm Colonias Designation
April 10 at 9 at County
- RD (Berino-Del Cerro/Mesquite LOC project)
meeting April 10 at 1:30 pm, Mesquite office

**LOWER RIO GRANDE PUBLIC WATER WORKS AUTHORITY
3/21/12 BOARD OF DIRECTORS MEETING
PROJECTS REPORT**

Authority Construction Projects:

LRG-11-01 - La Mesa Water System Improvements – Molzen Corbin – Bid Stage – RD - \$2,040,346: Bid opening was 3/1/12, and Engineer's Recommendation for Bid Award is on today's agenda. Burn Construction was low bidder.

LRG: 11-02.1 -Mesquite Wastewater Project – Gannett Fleming– BID Stage - \$7,262,081: County Engineering Dept. approved reduced paving and delayed base-course replacement for dirt roads. Contract documents have been executed and sent to RD, and we are still awaiting closing instructions. Application is being prepared to the CITF for the unfunded bid lots. Changed title companies for this and the La Mesa Well Project due to the first company's inability to issue policies unless the value of the property met or exceeded the loan component of the funding, should have binder by 4/1/12.

LRG-11-02.2 - Authority/Brazito Sewer Project – Vencor – Planning Stage – CDBG/SAP: Met w/engineer on 2/13/12, they will have environmental reports and sewer model complete by mid-April.

LRG-11-03 – Interconnect & Looping Project – Preliminary Phases are complete, funding applications have been submitted for interconnects to Brazito & Alto de Las Flores MDWs, and additional phases will be included in PER Vencor is preparing.

LRG-11-03.4 Mesquite/Brazito Water Emergency Water Interconnect & Supplemental Wells – Planning/Funding: Vencor has a preliminary map and has developed a project budget. Funding application has been submitted to NAD Bank/BECC CAP.

LRG-11-04 - Berino & Mesquite/Del Cerro combined Project – Letter of Conditions/final design & review of plans & specs – RD - \$5,420,147/WTB - \$4,371,630: WTB Quarterly Report is being prepared for 3/31/12 deadline. WTB portion should be ready to bid in a few weeks. Plans & specs for RD portion of project will be submitted to RD, NMED-CPB & DWB and DAC by 3/30/12. Next teleconference with RD is 4/10/12. Expected completion date for the LOC notebook is well before the August deadline. Project budget is below.

LRG-11-05 – Surface Water Treatment Plant – Design phase - PER (approved) & EID (approved 11/18/11) completed by CE&M, USDA-RD NOI published 7/9/11, public meeting 7/20/11. WTB application received legislative authorization, Capital Outlay was vetoed by the governor. Will present the project to the Water Trust Board on 3/28/12, and will be applying to NMFA for a planning grant.

LRG-12-03 – Authority-Alto de Las Flores Interconnect – planning - supplemental well applications for LRGPWWA & ADLFMDWCA have been submitted to NM-OSE, application has been submitted to NM-DFA for 2009 & 2010 Colonias Initiative Surplus Funds.

Authority PERs/EAs/40 Yr. Water Plan:

LRG-12-01 – Authority PER – prelim. planning: CDBG Planning Grant Application \$50,000 awarded 1/9/12. Staff & engineer are working with Tiffany Bloom at SCCOG to complete grant agreement documents.

Forty-Year Water Plan – CE&M – complete: pending NM-OSE comments/approval.

Return Flow Credit Plan – CE&M – GF – Pending Review: Drafted and submitted to Ms. Thacker at local NM-OSE 12/21/11.

Radio Read Meters – in-house – SRF Fund: Project Interest Form for funding request of \$595,000 was approved at 25% subsidized + 25% grant = 50% grant, 50% loan at 0%. NMFA delayed this to the April agenda because our financial statements do not show the required coverage ratio. We submitted the RCAC Rate Study stamped and approved by Vencor Engineering because they have precedent (with Albuquerque/Bernalillo Authority) for using budget projections based on a rate study by an engineering firm in lieu of the required coverage based on financial statements. Should be on NMFA agenda 4/27/12.

Individual MDWCA Projects under construction:

Mesquite Water Project – Gannett Fleming – Construction complete, pending close-out:

Work is complete, final disbursement of RD funds was received 11/10/11. Still pending as-builts from Smithco and O&M manual from Gannett. Hold up seems to be Siemens & their sub, Bob Kozojet.

LRG MDWA Projects:

Castillo Rd - La Mesa/Mesquite Interconnect – CE&M – construction incomplete: Bridge crossing pipe has been replaced and passed pressure test. Contractor will provide as-builts for NM-DOT permit, and final invoice will be paid when we have those.

La Mesa Building (jointly funded by La Mesa & LGRMDWA) – Molzin Corbin – under construction - NMED - SAP08-3099, Colonias 09-3118: 11 pay requests have been submitted, 8 have been paid. Change Order #1 was credit to us of about \$3,400 and a time extension of 148 days, CO #2 extended the time for the project with substantial completion by 4/9/12, Final on 4/26/12. CO #3 is being prepared to add a light fixture for the sign, panic buttons to the alarm system, a video security system, phone system, equipment to establish an intranet/LAN, and adjust the furniture allowance. Nearly all submittals are complete. Furniture will be in by completion date. Application has been submitted to Art In Public Places Program (1% of state funds for buildings goes to this program to provide a piece of art for the building), and it will be this summer before the piece can be selected.

Other projects:

Website: Board Minutes Page is up to date. Home & About Us pages are updated. Rate Study documentation is posted on the Notices page.

EBID Surface Water Treatment Plant – no further news

Legislative Report – Final report has been posted for 2012.

J. Paul Taylor Social Justice Symposium “Quality of Life as Social Justice” – Application forms were posted at the Board’s file storage site for those who would like to attend.

Rate Hearing – All deliverables have been received from Medius, Inc. Staff responses have been sent to all who had comments or questions and the Q&A has been posted on the website.

PROJECT BUDGET - BERINO/MESQUITE-DEL CERRO WATER SYSTEM IMPROVEMENTS						
Funding Sources	\$ Funds	Notes:				
RUS Loan FY 2011	\$2,304,000.00					
RUS Colonias Grant FY 2011	\$3,116,147.00					
Lower Rio Grande MDWCA Gen	\$6,553.00					
NMDFA 08-L-G-3449	\$200,000.00					
NMED SAP 09-3356-GF	\$70,000.00					
NMED SAP 07-4442-GF	\$46,079.00					
NMED SAP 08-3846 GF	\$120,000.00					
NMED SAP 07-4446-GF	\$76,474.00					
NM Finance Authority #2361-P0	\$49,920.00					
Water Trust Board Loan 223-WT	\$437,163.00					
Water Trust Board Grant 223-W	\$3,934,467.00					
Total Project Funds:	\$10,360,803.00					
Project Expenses			Budget \$	Expended	%Complete	Remaining
Construction			\$7,381,050.00		0%	\$7,381,050.00
Construction NMGR (Dona Ana County)			\$463,072.00		0%	\$463,072.00
Construction Observation Services			\$288,337.00		0%	\$288,337.00
Contingencies			\$681,892.00		0%	\$681,892.00
EBID & Dona Ana County Permits (Del Cerro Ph IV)			\$5,000.00		0%	\$5,000.00
Legal Services			\$147,621.00		0%	\$147,621.00
RCAC Origination Fee and Interest			\$60,000.00		0%	\$60,000.00
Preliminary Engineering Report (Del Cerro Ph IV)			\$42,000.00	\$42,111.00	100%	-\$111.00
Environmental Report (Del Cerro Ph IV)			\$46,000.00	\$46,000.00	100%	\$0.00
Water Model (Del Cerro Ph IV)			\$15,000.00	\$19,741.00	132%	-\$4,741.00
Project Easements - 250 (Del Cerro Ph IV)			\$249,127.00	\$200,000.00	80%	\$49,127.00
Project Base Maps (Del Cerro Ph IV)			\$18,000.00	\$17,958.00	100%	\$42.00
Engineering Design & Specifications			\$630,756.00	\$422,079.26	67%	\$208,676.74
Project Soils/Geotech Studies/Report			\$43,500.00	\$29,375.00	68%	\$14,125.00
Project Surveys (Del Cerro Ph IV)			\$60,726.00	\$41,480.00	68%	\$19,246.00
Traffic Control Plans & SWPPP Plans (Del Cerro Ph IV)			\$22,780.00	\$10,000.00	44%	\$12,780.00
Other - Project Reimbursables			\$27,891.00	\$2,283.96	8%	\$25,607.04
Professional Services NMGR			\$178,051.00	\$61,793.54	35%	\$116,257.46
Total Project Expenses:			\$10,360,803.00	\$892,821.76	9%	\$9,467,981.24

Lower Rio Grande PWWA

Operators Report

March 21, 2012

System Problems and Repairs.

- Backflow inspections are current.(Mesquite District)
- Sewer tank inspections are current.(Mesquite District)
- No Major problems with the Lower Rio Grande system.
- 3 new services in the Berino district.
- 2 new services in the Desert Aire.
- 3 new services in the Mesquite district.
- We had a few small water leaks in the mesquite district and a few in the Berino district.
- The gas chlorine unit At Well #4 is working well, we just went through our first bottle early this month.
- Kathi, Mike , and Javier have finished Asset Management.
- The Well in Desert Aire failed in late February.

NMED: Monthly Bac-T-Samples have been taken for the Lower Rio Grande PWWA, La Union, Desert Aire, and Butterfield Park.

Mesquite district Wetlands: wetlands have been working fine

Chlorine: No problems with Chlorine this month.

Reports: NMED, State Engineers, and the water conservation reports have been sent.



LOWER RIO GRANDE

Public Water Works Authority

325 Holguin Road Box C

Vado, New Mexico 88072

(575) 571-3628

www.LRGauthority.org

Questions from March 6, 2012 Public Rate Hearing With Staff Responses

Elario Gomez: Mr. Gomez asked a question about the standpipe in Mesquite.

Response: Thank you for attending the hearing and for your question. That standpipe is not an LRGPWVA facility. An independent contractor is using it to fill water trucks for a construction project on the east side of I-10. The individual property owner allowed the temporary tank to be located on their property which is near a fire hydrant. The LRGPWVA is selling water to the contractor at bulk rates as outlined in our Bulk Water Agreement.

Arturo Uribe, 114 Emerson, PO Box 95, Mesquite NM:

Q-1. Why was the rate analysis done now?

Response: Thank you for coming to the hearing and for your questions and comments. The rate analysis was required as part of the USDA-RD funding for the projects outlined in the presentation, and this should be done on an annual basis as part of the annual budget process anyway.

Q-2. What is the impact to the elderly and low income residents and members?

Response: First of all, the residential minimum charge remains the same as before. The usage charges are based on consumption for individual households. The impact will vary according to water consumption, but for example, the average household uses about 6,000 gallons of water per month, and the impact on an individual's water bill at that level of usage \$1.50. The current bill for 6,000 gallons usage is 19.00 + NMGRT, and at the proposed rates it will be \$20.50 plus tax.

Q-3. Why does the rate increase need to be implemented now?

Response: It is a condition of our funding, and not implementing it will jeopardize that funding and those projects.

Q-4. What would happen if the rate increase is not adopted at the 3-21-12 meeting?

Response: Projects may be delayed and funding could be de-obligated for projects.

Q-5. We have to pay rate increases for all the utilities and the additional water rate increase poses a concern to the citizens of Mesquite?

Response: This rate increase is for new infrastructure, and is a condition of the funding.



LOWER RIO GRANDE

Public Water Works Authority

325 Holguin Road Box C

Vado, New Mexico 88072

(575) 571-3628

www.LRGauthority.org

Q-6. You spoke earlier of the meter reading may not have been accurate in the past. What is the impact that now the new meters will have on our water rates?

Response: *It is an industry standard to replace meters every five years, and some of our meters have been in place since the 1960s. With older meters, the inaccuracy tends to be that they read less than actual usage, thus homes with newer meters paying their true usage, while older homes may not be. Additionally, the new radio-read meters will reduce the possible human error factor because the usage is uploaded digitally into the billing system and verified. This not only reduces potential errors in meter reading, it reduces the labor involved in meter reading, helping us keep our costs down.*

Q-7. Regarding the acquisition of the Mesquite Community Center. I was involved in the negotiations with the County, namely Brian Haines as a member of the Mesquite Community Action Committee. There is a standing contract with the Mesquite Community Action Committee in place that puts us in charge of the facility. What will be the impact to the citizens and my organizations if the building is transferred to the LRG PWWA.

Response: *At this stage, the transfer is only a concept. Dona Ana County has inquired whether the LRG PWWA would be interested in assuming ownership of the Center. Any contracts between the county and other individuals would not be applicable to the LRG PWWA, thus new contracts would need to be negotiated. Additionally, the LRG PWWA would have to determine how the Center would be used.*

Espy Holguin, 615 Holguin Street: This presentation today revealed that the water rate increase is less than the percentage that we receive from the electric or gas company in the area. I have been a member of the Vado Water Association since the 1980's. The benefits/improvements that we have received in the improved fire safety, the improved water pressure and the conservation of water are important. We need to make sure that we now conserve our water usage to make sure that we have adequate water provision for our elderly. I was the manager for the Sunland Park Water Department and a member of the Vado Water system for more than 15 years. I know that proposed rates will not affect the elderly because their water usage is far below the minimal rate so they won't be affected by the rate change. The rate change has not changed in more than 15 years. In fact it has gone down. When I hooked up to the system in 1982, my minimum rate was \$12.50. Now it is \$10.00 so I have benefitted from the regionalization. I don't need a response; I am simply making a comment. I commend you for the presentation.

Response: *Thank you for your comments and for taking the time to attend this hearing.*

Orlando Jimenez, 306 St. Valentine, La Mesa, NM: Expressed his concerns with the large increases in the base rate for commercial users. He understands the need for the increase but the commercial rates



LOWER RIO GRANDE

Public Water Works Authority

325 Holguin Road Box C

Vado, New Mexico 88072

(575) 571-3628

www.LRGauthority.org

will change substantially. He expressed his concerns on behalf of his auntie, owner of Chope's. Most businesses are open right now so they are not able to attend this meeting. He expressed his request to send a letter to the area businesses to share the commercial rate increase with justification to the commercial users. He thought it would be a nice gesture to extend the olive branch of peace so that they will be more receptive of the increases.

Response: *Thank you for your role in this hearing and for your comments and questions. The rate study was mentioned in our January newsletter, hearing notices were posted at many local businesses throughout our eight communities, in the newspaper, and on television. Also, the April newsletter, will again inform customers of the new rates if they are adopted by the board on 3/21/12. Businesses use more of our resources and are being asked to pay more under the proposed rates because of that.*

Irene Pena, Tierra del Sol: Had a question about using the parks as a water reservoir to conserve water as well as provide a place for public use.

Response: *Thank you for your question and for taking the time to attend the hearing. Our water source is wells pumping groundwater and stored in above-ground tanks, and we do not use reservoirs.*

America Terrazas, 121 La Fe, Del Cerro, NM: ‘

Q-1. Now that the systems have been connected, and there is a study done every year on the rates, does this mean that the rates will be increased every year as a result of the study?

Response: *Thank you for your questions and comments and your attendance at this hearing. No. The annual rate studies in conjunction with development of the annual budget are tools that the LRGPWWA use to control expenses and identify projected revenues.*

Q-2. The other question is on the management and ownership of the Mesquite Community Center? Does the LRG have the funds, staff and resources to operate a Center? Do the LRG users have the funds to pay for the operations and maintenance of the facility? I want clarity on who will pay for the operations. Will users be responsible for paying for the use and operation of the facility?

Response: *Should the transfer be approved by both Dona Ana County, the LRGPWWA and possible the New Mexico Department of Finance & Administration, the LRGPWWA would assume ownership as well as management of the Center. A separate revenue stream would be used to pay for staff resources, operation and maintenance of the Center. The utility customers would be responsible should the LRGPWWA decide to use the Center as a headquarters for the operation of the Authority. Other than that, the LRGPWWA would seek separate funding for the operation of the Center.*



LOWER RIO GRANDE

Public Water Works Authority

325 Holguin Road Box C

Vado, New Mexico 88072

(575) 571-3628

www.LRGauthority.org

Gerardo Jimenez, 123 La Fe, Del Cerro, NM: Commented that gas and electricity cost more because those services cost more to generate. I pay \$77 for gas. The electricity is even more. I don't know why the water rates are increasing? The water comes from the ground; it doesn't take much money to generate the water. I need an explanation of why the water is being increased when the electricity and gas costs more to generate so I understand why those rates increase. I just wanted to make the comment. I don't understand why the water rate is increased. I don't need an explanation.

Response: *Thank you for coming to the hearing and for your comments. This rate study and proposed increase is a condition of our funding, not implementing it will jeopardize that funding and those projects identified in the presentation, but the LRGPWWA has numerous expenses involved in providing water service to our customers including wages & salaries, electrical and other utilities, treatment costs, audits, legal fee, etc. which pay for delivering to your home. Our financial statements are available at our office and are contained our public information available on our website.*

Dora Dorado, 129 Lomas, Del Cerro, NM: Thank you for this hearing. I have been hearing for some time that funds were being generated to improve our water system. I have been seeking reasons and justification for the regional system. When we first regionalized, I was under the impression that because there were more customers connected that the rates wouldn't go up or down, they would stay the same. I don't see any dairy owners at this meeting. I believe that the residential increase is not bad. The \$.50 per 1,000 gallons commercial rate increase is a minor increase. I am worried about the Senior citizens and their ability to pay for their bills if an increase is implemented. I also have concern for the families with small children and as summer approaches that their water consumption will be increased and their rates will increase. I am hoping that the County does not raise our sewer rates as a result of the water rate increase. What about the large trucks that gets water from the water hydrants. Who pays for that water?

Response: *Thank you for your comments and question. To clarify the impact of regionalization on water rates, a larger customer base does reduce the impact of expenses as they are reflected in the rate schedule because those expenses are shared by so many more connections. For example, the rate study done for Mesquite MDWC & MSWA by Rural Community Assistance Corporation prior to the merger proposed a much larger rate increase for the Mesquite customers to cover the debt service for the loan component of the Mesquite-Del Cerro Project than the \$.25 per thousand gallons our rate study recommends to cover the entire \$3,509,663 combined new debt service for the whole region and all of the projects shown in the presentation. Our water rates are less than the state average and are completely independent of the county's sewer charges. Bulk water sales to contractors through our fire hydrants are metered and billed to the purchaser under a Bulk Water Sales Agreement. Those contractors pay a much higher rate, and that Agreement may be viewed at our website.*

Felipe Salas, PO Box 8, Mesquite NM:



LOWER RIO GRANDE

Public Water Works Authority

325 Holguin Road Box C

Vado, New Mexico 88072

(575) 571-3628

www.LRGauthority.org

Q-1. If there is improvements made and we are to pay for it, are we going to receive better service as a result of the increase? If something happens, will you come out faster to service us?

Response: *Thank you for your questions and for attending the hearing. The improvements will provide better service, including larger water mains and additional fire hydrants, which is separate from our response time. Response time will vary according to circumstances, time of day, how quickly we are notified of a problem, and the location of the on-call employee.*

Q-2. I have a concern that we are getting a \$.25 increase and the businesses aren't? Is that equitable?

Response: *You are correct. The increase per thousand gallons for commercial accounts is \$.50. Also, the minimum charge for commercial accounts will increase from \$13 to \$30, while the residential minimum will remain unchanged at \$10.*

Q-3. When will the projects contemplated start?

Response: *One of the projects is expected to begin in the Spring of 2012, another in the Summer of 2012, and the radio-read meters will be an on-going project for up to two years as meters are changed out.*

Q-4. Is this public input or does my comment make a difference in the decisions that are made? In reality, does my comment or opposition make a difference?

Response: *Yes. This is a public hearing, we are seeking your input, and it will be fully reported to the Board of Directors. These projects were approved by the memberships of the individual mutual domestic associations several years ago, prior to their merger into the LRGPWVA. The goal of this hearing is to inform you about the results of the rate study and how our rates will be impacted by these improvement projects. Had the LRGPWVA rates been set higher to begin with, an increase might not have been needed at this time, but that would have cost customers more in the long run.*

Q-5. What is the impact of new connections and rates to the existing users? Will the costs be shared by the new users?

Response: *The intent of these projects is not to add new connections, thus connection fees will continue at the current amounts identified in our policies. The impact to existing and new users will be the proposed rate increase, if approved. Those impacts were detailed in our presentation.*



Lower Rio Grande Public Water Works Authority

Water Rate Public Hearing

March 6, 2012

2012 Water Project Funding Summary

GRAND TOTAL Project Grants	\$9,479,933.00
GRAND TOTAL Project General Funds	\$6,553.00
GR. TOTAL Project Loans - RD* *RD Loans are 40 year term	\$3,212,163.00
GR. TOTAL Project Loans - NMFA* *NMFA Loans are 20 year term	\$297,500.00
GRAND TOTAL PROJECT FUNDS	\$12,996,149.00
Total Loans factored into Rate Study	\$3,509,663.00

PROJECT BUDGET Berino/Mesquite-Del Cerro Water Project

Funding Sources	\$ Funds
RUS Loan FY 2011	\$2,304,000.00
RUS Colonias Grant FY 2011	\$3,116,147.00
Lower Rio Grande MDWCA General Fund	\$6,553.00
NMDFA 08-L-G-3449	\$200,000.00
NMED SAP 09-3356-GF	\$70,000.00
NMED SAP 07-4442-GF	\$46,079.00
NMED SAP 08-3846 GF	\$120,000.00
NMED SAP 07-4446-GF	\$76,474.00
NM Finance Authority #2361-PG	\$49,920.00
Water Trust Board Loan 223-WTB 2011	\$437,163.00
Water Trust Board Grant 223-WTB 2011	\$3,934,467.00
Total Project Funds:	\$10,360,803.00
Total Grant Funds:	\$7,613,087.00
Total Loan Funds:	\$2,741,163.00
Total General Funds:	\$6,553.00

Project is in final design & review -- should bid by May

PROJECT BUDGET La Mesa Well Project

Funding Sources	\$ Funds
USDA RD Grant	\$1,569,346.00
USDA RD Loan	\$471,000.00
Total Project funds:	\$2,040,346.00
Total Grant Funds:	\$1,569,346.00
Total Loan Funds:	\$471,000.00

Project is currently out to bid

PROJECT BUDGET Radio-Read Meters

Funding Sources	\$ Funds
DWSRLF Grant	\$148,750.00
DWSRLF Subsidized Loan (aka Grant)	\$148,750.00
DWSRLF Loan @ 0%	\$297,500.00
Total Project Funds:	\$595,000.00
Total Grant Funds:	\$297,500.00
Total Loan Funds:	\$297,500.00

Project was approved by NMED, Application has been submitted to NMFA and is pending review

A look at the whole LRG regional water system funding picture so far...

Lower Rio Grande Mutual Domestic Water Association Funds Water System Interconnect Projects, Regional Planning & Merger

2007 Grant	Colonias Initiative	\$300,000.00
2007 Grant	Legislative Capital Outlay	\$660,000.00
2008 Grant	Colonias Initiative	\$223,952.76
2008 Grant	Colonias Initiative	\$160,000.00
2009 Grant	NM-DFA CDBG	\$500,000.00
2009 Grant	Colonias Initiative	\$312,047.24
2009 Grant	Colonias Initiative	\$462,293.00
2009 Grant	Colonias Initiative	\$400,000.00
2009 Grant	NM-DFA CDBG Planning	\$100,000.00
Total Grant Funds - LRGMDWA		\$3,118,293.00
Total Grant Funds - LRGPWWA		\$9,479,993.00
Total Loan Funds - LRGPWWA		\$3,509,663.00
Total LRG Regional Water Project Funds		\$16,107,949.00

NOTE: This does not include 2012 Grant **\$345,000.00**
from Legislative Capital Outlay awaiting the Governor's
Signature. The new Total would be **\$16,452,949.00**



Rate Analysis Process

- Mandated by USDA – RD as part any federally funded project
- Letter of Conditions (LOC) requires that RCAC performs the rate analysis to determine fiscal capacity
- The analysis concluded that a rate increase was needed to meet new operating expenses, new debt and new reserve requirements

Rate Analysis Process cont'd.

- Rates should be reviewed and updated every year as part of the annual budget development process
- A properly developed rate structure will:
 - Create equity among customer categories
 - Creates operational sustainability
 - Enables utility to secure public funds
 - Encourages water conservation

Current Water Rates

Residential Water Rates

Minimum Bill		\$ 10.00	for				0	gallons
Tier 1	0-10,000	gallons	for	\$ 1.50	per	1,000	gallons	
Tier 2	10,001-20,000	gallons	for	\$ 1.75	per	1,000	gallons	
Tier 3	20,001-30,000	gallons	for	\$ 2.00	per	1,000	gallons	
Tier 4	30,000-50,000	gallons	for	\$ 2.25	per	1,000	gallons	
Tier 5	Over 50,001	gallons	for	\$ 2.50	per	1,000	gallons	

Commercial Water Rates

Minimum Bill		\$ 13.00	for				0	gallons
Tier 1	0-20,000	gallons	for	\$ 2.00	per	1,000	gallons	
Tier 2	20,001-50,000	gallons	for	\$ 2.50	per	1,000	gallons	
All over	All over 50,0001	gallons	for	\$ 3.50	per	1,000	gallons	



Proposed Water Rates

Residential Use and Income Estimate:							
Minimum Bill	\$ 10.00	for				0	gallons
Tier 1	0-10,000	gallons	for	\$1.75	per	1,000	gallons
Tier 2	10,001-20,000	gallons	for	\$2.00	per	1,000	gallons
Tier 3	20,001 -30000	gallons	for	\$2.25	per	1,000	gallons
Tier 4	30,001 - 50,000	gallons	for	\$2.50	per	1,000	gallons
Tier 5	All over 50,001	gallons	for	\$2.75	per	1,000	gallons

Commercial Use and Income Estimate:							
Minimum Bill	\$30.00	for				0	gallons
Tier 1	0-20,000	gallons	for	\$2.50	per	1,000	gallons
Tier 2	20,001 - 50,000	gallons	for	\$3.00	per	1,000	gallons
All over	All over 50,0001	gallons	for	\$4.00	per	1,000	gallons

Rate Comparison

RESIDENTIAL RATES			Current	NEW	
Mininum Bill			\$ 10.00	\$10.00	0 gallons
Tier 1	0-10,000	gallons	\$1.50	\$1.75	per 1,000 gallons
Tier 2	10,001-20,000	gallons	\$1.75	\$2.00	per 1,000 gallons
Tier 3	20,001 -30000	gallons	\$2.00	\$2.25	per 1,000 gallons
Tier 4	30,001 - 50,000	gallons	\$2.25	\$2.50	per 1,000 gallons
Tier 5	All over 50,001	gallons	\$2.50	\$2.75	per 1,000 gallons
Cost at 6,000 gallons usage			\$19.00	\$20.50	
Statewide average cost of 6,000 gallons				\$23.71	

COMMERCIAL RATES			Current	NEW	
Mininum Bill			\$13.00	\$30.00	0 gallons
Tier 1	0-20,000	gallons	\$2.00	\$2.50	per 1,000 gallons
Tier 2	20,001 - 50,000	gallons	\$2.50	\$3.00	per 1,000 gallons
All over	All over 50,0001	gallons	\$3.50	\$4.00	per 1,000 gallons
Cost at 6,000 gallons usage			\$25.00	\$45.00	

Rate Comparison

Usage and Charge-Water			
Water			
Minimum Charge			
Old Residential	New Residential	Old Commercial	New Commercial
\$ 10.00	\$ 10.00	\$ 13.00	\$ 30.00
6,000 gallons			
Residential		Commercial	
Old	New	Old	New
\$ 19.00	\$ 20.50	\$ 25.00	\$ 45.00
10,000 gallons			
Residential		Commercial	
Old	New	Old	New
\$ 25.00	\$ 27.50	\$ 33.00	\$ 55.00
20,000 gallons			
Residential		Commercial	
Old	New	Old	New
\$ 52.50	\$ 57.50	\$ 53.00	\$ 80.00

Rate Implementation Schedule

- Proposed rate scheduled has been approved by USDA – Rural Development for implementation
- Board will consider the proposal and all comments at the March 21st board meeting
- Implementation potentially April 1, 2012

On Another Topic...

- The Lower Rio Grande Public Water Works Authority is collaborating with Doña Ana County to possibly take over ownership of the Mesquite Recreation Center and park at 129 Tawa, and we would like your input on that as well.



LOWER RIO GRANDE Public Water Works Authority



- [Home](#)
- [About Us/Quienes Somos](#)
- [Customer Service](#)
- [Board of Directors](#)
- [Board Minutes](#)
- [Notices/Avisos](#)
- [Events/Eventos](#)
- [Documents/Documentos](#)
- [Contact Us/Contactenos](#)
- [Projects & Planning](#)
- [RFPs/Purchasing Info](#)
- [Photos/Galeria de fotos](#)
- [Blog](#)

Welcome

[Español](#)

The Lower Rio Grande Public Water Works Authority was formed by the merger of five water systems, Berino MDWC & MSWA, Desert Sands MDWCA, La Mesa MDWCA, Mesquite MDWC & MSWA and Vado MDWCA under state statute NMSA 1978 73-26-1 (2009 House Bill 185). Serving the residents of eight Colonias communities in southern Dona Ana County, New Mexico, the water systems have merged into a single entity. This new Authority gives the communities the ability to resolve many challenges that were previously affecting all five associations. The formation of the Authority has also created additional benefits, such as:

- Creation of economies of scale resulting in lower rates for customers
- Reduction and/or elimination of duplication of efforts
- Establishment of a defined service area
- Increase technical, managerial and financial capacity
- Increased efficiency of operations with appropriate level of staffing
- Increased ability to comply with regulations
- Increased ability to secure funding
- Increased drinking water reliability
- Increased accountability and oversight
- Increased transparency

This website will keep the communities we serve and our



LOWER RIO GRANDE
Public Water Works Authority



LOWER RIO GRANDE
Public Water Works Authority

Thank You!

Thank you very much for
being here and giving us
your feedback!

Our Web Site – www.LRGauthority.org

Email us – info@LRGauthority.org





LOWER RIO GRANDE

Public Water Works Authority

325 Holguin Road Box C

Vado, New Mexico 88072

(575) 571-3628

www.LRGauthority.org

Lower Rio Grande Public Works Authority Election Policy

1. Definitions.

As used in the Lower Rio Grande Public Water Works Authority Election Policy:

- A. "Authority" means the Lower Rio Grande Public Water Works Authority, a legal entity created through legislative action under NMSA 1978 §73-26-1 (2009).
- B. "board" means the governing authority
- C. "election" means a regular or special election but does not include a recall election.
- D. "filing officer" means the Authority General Manager
- E. "Authority election official" means the Authority General Manager
- F. "member in good standing" means a person who has complied with Section 2.01 of the Authority Governance Document and whose service has not been deactivated or disconnected for non-payment

2. Elections; registration.

- A. A list of registered electors for each Authority voting district shall be maintained by the Authority General Manager and provided to the Doña Ana County Clerk at least twenty-eight (28) days prior to the election.
- B. In order to register with the Authority as an elector, a person must:
 - (1) Own real property within the Authority's recorded designated service area;
 - (2) Receive services provided by the Authority to that property; and
 - (3) Be a member as defined in the Governance Document of the Authority
- C. The list of registered electors will be closed sixty (60) days prior to the election and reopened the day after the election.

3. Elections; qualifications of candidates.

- A. An election shall be held to elect qualified members to the board of directors. No persons shall become a candidate for the board unless they meet all of the following requirements:
 - (1) He/she owns real property within the Authority's recorded designated service area;

- (2) He/she receives services provided by the Authority to that property;
- (3) He/she is a member in good standing of the Authority; and
- (4) He/she may run for election only for the district in which he/she is a voting member.

B. A regular election shall be held on the first Tuesday in April of each odd-numbered year.

C. An election held at any time other than the date for the regular election shall be a special election.

D. Except as otherwise provided in this Election Policy, elections shall be called, conducted, and canvassed as provided in the Election Code [NMSA 1978, Sections 1-24-1 through 4 and other relevant provisions of Chapter 1].

4. Regular election; proclamation; publication.

A. The Authority board by resolution shall issue a public proclamation in Spanish and English calling for a regular election on the date prescribed by this Election Policy. The proclamation shall be filed by the board chair with the Doña Ana county clerk no later than the last Tuesday in January of the odd-numbered year in which the election is to be held.

B. The proclamation shall specify:

- (1) the date when the election will be held;
- (2) the purpose for which the election is held;
- (3) the positions on the board to be filled;
- (4) the date on which declarations of candidacy are to be filed;
- (5) the districts within the Authority for which board positions are to be filled and the location of each polling place;
- (6) the hours each polling place will be open; and
- (7) the date and time of the closing of the registration books by the county clerk of record as required by law.

C. After filing the proclamation with the county clerk of record and not less than fifty-six days before the date of the election, the county clerk of record shall publish the proclamation for two consecutive weeks in a newspaper of general circulation within the Authority's designated service area.

5. Special election; proclamation; publication.

A. Whenever a special election is to be called or is required, the board shall by resolution issue a public proclamation in Spanish and English calling the election. The proclamation shall forthwith be filed by the board president with the county clerk of record.

B. The proclamation shall specify:

- (1) the date on which the special election will be held;

- (2) the purpose of the special election;
- (3) the question(s) to be submitted to the voters;
- (4) the location of each polling place;
- (5) the hours each polling place will be open; and
- (6) the date and time of the closing of the registration books by the Authority election official.

C. After filing the proclamation with the county clerk of record and not less than fifty-six days before the date of the election, the county clerk of record shall publish the proclamation weekly for two consecutive weeks in a newspaper of general circulation within the Authority's designated service area.

6. Districts; polling places.

- A. The same districts that are used in a general election shall be used in a special election.
- B. The county clerk shall consolidate Authority districts for an election as provided in the proclamation for that election and provide for a polling place(s) within each Authority district or consolidated district.

7. Declaration of candidacy; filing date; penalty.

- A. A candidate for a board position that will be filled at a regular election shall file a declaration of candidacy with the proper filing officer during the period commencing at 9:00 a.m. on the third Tuesday in February of the odd-numbered year immediately preceding the date of the regular election and ending at 5:00 p.m. on the same day.
- B. A candidate shall file for only one board position during a filing period.
- C. Whoever knowingly makes a false statement in his declaration of candidacy is guilty of a fourth degree felony and shall be sentenced pursuant to the provisions of NMSA 1978, Section 31-18-15.

8. Declaration of candidacy; sworn statement of intent; form.

In making a declaration of candidacy, the candidate shall submit a sworn statement of intent in substantially the following form:

"DECLARATION OF CANDIDACY - STATEMENT OF INTENT

(Must be filed the 4th Tuesday in February of the odd-numbered year immediately preceding the date of the regular election)

I, _____, (candidate's name on certificate of registration) being first duly sworn, say that I am a voter registered in District No. _____ of the Lower Rio Grande Public Water Works Authority, County of Doña Ana, State of New Mexico. I reside at _____ and was a qualified member of the Authority on the date of the Authority's board's proclamation calling the election for which I am a candidate.

I desire to become a candidate for the Authority's board of directors for District Number _____ at the Authority election to be held on the date set by law;

I will be eligible and legally qualified to hold this office at the beginning of its term;

I swear under oath that I have no record of crime or conviction designated under state or federal law;

I am not related by marriage or in kinship a standing board member;

I am not a current director, officer, employee, contractor, or elected or appointed official of any public or private utility that provides the same services as the Authority; and I make the foregoing affidavit under oath, knowing that any false statement contained herein constitutes a felony punishable under the criminal laws of New Mexico.

(Declarant)

(Mailing Address)

(Residence Address)

Subscribed and sworn to before me this _____ day of _____, 20_____.

(Notary Public)
My commission expires: _____”

9. Withdrawal of candidates.

- A. A candidate seeking to withdraw from a regular election shall withdraw no later than the thirty-fifth day before the date of the election by filing a signed and notarized statement of withdrawal with the proper filing officer.
- B. The county clerk shall not place on the ballot the name of any candidate who timely filed a statement of withdrawal.
- C. In withdrawing a declaration of candidacy, the candidate shall submit a sworn statement of intent in substantially the following form:

“DECLARATION OF WITHDRAWAL OF CANDIDACY - STATEMENT OF INTENT

(Candidate’s name will not appear on ballot if filed before 5:00 p.m. on the 35th day preceding the date of the election)

I, _____, (candidate’s name on Declaration of Candidacy) being first duly sworn, say that I am a Declared Candidate in District No. _____ of the Lower Rio Grande Public Water Works Authority, county of Doña Ana, State of New Mexico having properly filed a Declaration of Candidacy – Statement of Intent on the required date.

I hereby withdraw my candidacy for election to the Authority’s board of directors and request that my name be removed from the ballot.

(Declarant)

(Mailing Address)

(Residence Address)

Subscribed and sworn to before me this _____ day of _____, 20_____.

(Notary Public)

My commission expires: _____”

10. Ballots.

A. The proper filing officer shall determine whether a candidate filing a declaration of candidacy is a qualified elector. If the candidate is deemed qualified and no withdrawal of candidacy has been filed as provided in this Election Policy, the proper filing officer shall place the candidate’s name on the ballot for the position specified in the declaration of candidacy. A declaration of candidacy shall not be amended after it has been filed with the proper filing officer.

B. Ballots for the election shall be prepared by the proper filing officer and printed by the thirtieth day preceding the election. The cost of printing the ballots shall be paid by the authority. The printed ballot shall contain the name of each person who is a candidate and the position on the board for which the person is a candidate. The ballot shall also contain any questions to be submitted to the voters as certified to the proper filing officer by the board.

C. Paper ballots shall be printed in a form in substantial compliance with the provisions of and in compliance with the provisions of the federal Voting Rights Act of 1965, as amended.

D. An election shall be a nonpartisan election, and the names of all candidates shall be listed on the ballot without party or slate designation. The order in which the names of candidates are listed on the ballot shall be determined by lot.

E. Voting machines shall be used for the recording of votes cast in an election, provided that paper ballots may be hand counted in lieu of using a voting machine to tabulate ballots for:

(1) Authority districts of less than two hundred potential voters; or

(2) elections in which only one candidate has filed a declaration of candidacy for each position to be filled at the election and there are no questions or bond issues on the ballot.

11. Publication of Notice of Election.

The proper filing officer for the Authority shall issue and publish a notice of election proclamation listing the name of each candidate for election to the board by District, the offices to be filled, each question to be submitted to the voters, if any, and the names of the voting districts for which offices are to be filled, and the name and location of all polling places. The publication shall be made once each week for two successive weeks, with the last publication being made within seven days but not later than two days before the date of the election. The names of the candidates shall be published in the same order and for the same positions as will appear on the ballot. The publication shall be in a newspaper of general circulation and shall conform to the provisions of the federal Voting Rights Act of 1965, as amended. The cost of the publication shall be paid by the Authority. A copy of the proclamation shall also be posted in a public building and shall be printed in Spanish and English.

12. Conduct of elections.

A. Except as otherwise provided in this policy, the Doña Ana county clerk shall administer and conduct the Authority's elections pursuant to the provisions of the Election Code for the conduct of general elections.

B. District board members for each polling place shall be appointed by the county clerk from among Authority members who meet the qualifications set forth in NMSA 1978, Section 1-2-7 and who reside within the Authority's designated service area. The number of members on each District board shall be as provided in NMSA 1978, Section 1-2-12(C). Vacancies on election day shall be filled as provided in NMSA 1978, Section 1-2-15.

C. In the event that only one candidate has filed a declaration of candidacy for each position to be filled at the election and there are no questions or bond issues on the ballot, the county clerk shall perform the duties of the district board and no other district board shall be appointed.

D. All costs associated with the elections shall be paid by the Authority.

13. Votes required.

A. The candidate receiving a plurality of the votes cast for a designated position on the board shall be elected to that designated position.

B. All questions submitted to the voters shall be decided by a majority of the voters voting on the question.

14. Canvassing board; duties.

A. The canvassing board for the canvass of the results of an election shall be composed of the Authority's general manager, who is the proper filing officer, the county clerk, and the designated or the presiding judge of the court, as the case may be.

B. Ballots cast in the election shall be transported by the presiding judge of the district board upon the closing of the polls to the office of the proper filing officer. Each ballot box shall have two locks. The key to one lock on each ballot box and one copy of the signature roster shall at that time be placed in a stamped, addressed envelope provided for that purpose and shall be mailed to the designated or the presiding judge.

C. Within three days after the date of the election, the canvassing board shall meet in the office of the proper filing officer and shall:

(1) canvass the returns in the same manner as county election returns are canvassed;

(2) determine the total number of persons voting in the election; and

(3) issue a certificate of canvass of the results of the election and send one copy of the certified results:

(a) to the Authority board;

(b) to the secretary of state; and

(c) to the proper filing officer to be filed in his office.

D. The canvassing board shall issue a certificate of election to each candidate which it determines to be elected.

E. The county clerk of record shall cause the results of the election to be published once in a newspaper of general circulation.

15. Election contests.

Any unsuccessful candidate for election to the board may contest the election of the candidate to whom a certificate of election has been issued. The procedure to be followed in contest cases shall be the same as provided by the Election Code [Chapter 1, Article 14, NMSA 1978].

16. Records.

The returns and certificates of the result of the canvass are public documents, subject to inspection during the customary hours and days of business. Signature rosters and tally sheets may be destroyed three years after the election to which they apply. The certificate of results of the canvass of the election shall, thirty days after the election or immediately after any contest has been settled by the court, be placed on file as a permanent record in the state records center. A copy of the certificate of results of the canvass of the election shall be kept on file in the office of the proper filing officer for a period of three years.

17. Absentee voting.

A. A voter may vote in an election by absentee ballot for all candidates and on all questions appearing on the ballot in his or her district as if casting a ballot in person at the polling place on election day.

B. The provisions of the Absent Voter Act [NMSA 1978, Chapter 1, Article 6] apply to absentee voting in Authority elections, provided that absentee ballots may be marked in person during the regular hours and days of business at the county clerk's office from 8:00 a.m. on the twenty-fifth day preceding the election until 5:00 p.m. on the Friday immediately prior to the date of the election. Absentee ballots shall be printed at least thirty days prior to the date of the election. Provisions may be made by the board in the proclamation for absentee voting by electronic voting machine from 8:00 a.m. on the twentieth day preceding an election until 5:00 p.m. on the Friday immediately prior to the date of the election.

C. A regular district board may be designated to serve as the absent voter district board. A member of the absent voter district board shall receive the same compensation as a regular district board member. A regular district board member who also serves as a member of the absent voter district board shall not be entitled to extra compensation for serving on the absent voter district board.

Adopted by the Board of Directors of the Lower Rio Grande Public Water Works Authority at its regular monthly meeting this 21st day of March, 2012 on a vote of ____ in favor, ____ opposed, ____ absent.

SEAL:

Roberto Nieto, Chairman

Attest:

Santos Ruiz, Secretary

**La Union MDS&WA and the Lower Rio Grande Public Water Works
Authority
O&M Interagency Agreement Amendment
Joint Resolution FY2012-01**

Whereas, the La Union MDS&WA and the Lower Rio Grande Public Water Works Authority, agree to amend the current Operation and Maintenance Interagency Agreement, and

Whereas, the amend of the current Operation and Maintenance Interagency Agreement shall be to extend for one (1) year, with the possibility of extension for two (2) additional years on a year by year bases for a total of four (4) years which can be terminated as outlined in the Agreement, and

Whereas, the La Union MDS&WA and the Lower Rio Grande Public Water Works Authority, agree to comply with the provisions of the current Operation and Maintenance Interagency Agreement, and

Therefore, be it resolved, that Both Board of Directors adopts and passes Joint Resolution FY2012-01 to amend by extension the O&M Interagency Agreement officially approved on _____, and _____.

PASSED, APPROVED, AND ADOPTED: _____ and _____ .

La Union MDS&WA

Lower Rio Grande PWWA

Jose Villalobos, President

Roberto M. Nieto, Chairman

ATTEST _____
Date

ATTEST _____
Date

Evangelina Martinez, Secretary

Santos Ruiz, Secretary

CERTIFICATION

I certify that:

We have the authority to request the funds described in this application and, upon award, will enter into a contract for the repayment of any Colonias Infrastructure Project Fund loans.

We will comply with all applicable state and federal regulations and requirements.

To the best of my knowledge all information contained in this application is valid and accurate and the submission of this application has been authorized by the governing body of the undersigned jurisdiction.

Signature: _____ Date: March 21, 2012
 Finance Officer/Director
Kathi Jackson, Finance Manager

Signature: _____ Board Chairman
 (Highest elected official) _____ Title

Print Name: Roberto Nieto Date: March 21, 2012

Jurisdiction: Lower Rio Grande Public Water Works Authority

Authorizing Fiscal Agent if applicable: Not Applicable

Signature: _____ Date: _____

MOLZENCORBIN

March 14, 2012

Ms. Karen Nichols
Projects Manager
Lower Rio Grande Public Water Works Authority
325 Holguin Road
Vado, New Mexico 88072

**RE: La Mesa Well No. 3
Recommendation of Award of Construction & Engineering Contract**

Dear Ms. Nichols,

Bids for the above referenced project were opened on March 1, 2012. A tabulation of the seven (7) bids received is enclosed. The lowest responsive bid submitted was from Burn Construction Company Inc. out of Las Cruces, New Mexico in the amount of **\$1,414,696.61** for total of all bid prices, excluding gross receipts tax which will be added to the contractor's billings.

Burn Construction Company Inc. is an active contractor in the state of New Mexico and possesses a GF09, GF98, GA98, GF04, GF01, GF02, GF03, and a GB-98, license number 1762 (verified by internet with the New Mexico Construction Industries Division at <http://www.rld.state.nm.us/construction/default.aspx>). Burn Construction Company Inc. bid bond was by The Gray Casualty & Surety Company, which is listed on Federal Circular 570 and are licensed to do business in New Mexico, within the limits of the project (verified via the internet at www.fms.treas.gov/c570 and by telephone with U.S. Department of the Treasury, Washington, D.C., Security Bond Branch, 202-874-6850). The Subcontractor listed for Well Drilling is HydroGeologic Services Inc. from Albuquerque, New Mexico, they are an active contractor in New Mexico with license number 1472 (verified by internet with New Mexico Office of the State Engineer at <http://www.ose.state.nm.us/PDF/WellDrillers/NM-WellDrillers-ByCompany.pdf>).

It is recommended that the bid be awarded to the low bidder Burn Construction Company Inc., subject to the approval of the Lower Rio Grande Public Water Works Authority board in the amount of \$1,414,696.61 plus gross receipts tax and construction contingencies. This project is being funded by USDA Rural Development with a Grant in the amount of \$1,569,346.00 and Loan of \$471,000 for a total of **\$2,040,346.00**.

The Engineering portion of this project has been done by Molzen Corbin based on a January 30, 2009 contract between Molzen Corbin and La Mesa Mutual Domestic Water Consumer Association. The terms of the contract are such that the Basic Engineering Services would be based on the USDA Rural Development curve, which is based on a percentage of the construction amount. Based on the low bid of \$1,414,696.61 the Basic Engineering Services is

Ms. Karen Nichols

March 14, 2012

La Mesa Well No. 3 Recommendation of Award of Construction & Engineering Contract

Page 2

7.7% of the construction amount or \$108,931.64; additional Engineering Services add an additional \$36,000 for a total Engineering Fee of **\$144,931.64** plus gross receipts tax. The Basic Engineering Services portion of the Fee will be adjusted again upon completion of Construction when all construction costs have been identified.

Additional costs for the project include Construction Observation and Hydrogeologist billed on a Time and Materials basis not to exceed **\$70,000** and **\$25,000** plus gross receipts tax respectively. Reimbursable expenses incurred during this project total **\$5,049.16**. Terms of the merger of the La Mesa Mutual Domestic Water Consumer Association and the Lower Rio Grande Public Water Works Authority require that an existing RIP loan with a balance of **\$57,187.95** be refinance as part of this project. This project has a contingencies budget totaling **\$215,148.90**.

It is recommended that the entire project including Construction, Engineering, Construction Observation, Hydrogeologist, Reimbursable expenses, RIP loan refinance, and contingencies be awarded subject to approval by the Lower Rio Grande Public Water Works Authority board in the amount of \$2,040,346.00. If you have any questions or comments, please feel free to contact us.

Sincerely,

MOLZEN-CORBIN



Wyatt D. Kartchner, P.E.

Enclosures:

Funding Analysis

Bid Tabulation

Lower Rio Grande Public Water Works Authority
La Mesa Well No. 3 Funding Analysis
March 14, 2012

Description	Amount	Comments
Engineering		
Basic Engineering Services **	\$ 108,931.64	Curve (7.7%)
Topographic Survey	\$ 10,000.00	Contract
Right-of-way Surveys	\$ 13,000.00	Contract
Geotechnical Report	\$ 5,000.00	Contract
Advertise/Bid/Award	\$ 3,000.00	Contract
Funding Administration	\$ 5,000.00	Contract
Subtotal Engineering	\$ 144,931.64	
NMGRT (7.5625%)	\$ 10,960.46	
Total Engineering	\$ 155,892.09	
Reimbursables		
Right of Way	\$ 386.00	BLM La Mesa Check No. 4862
Legal	\$ 202.95	La Mesa Check No. 5091
Special Use Permit	\$ 3,416.67	EBID La Mesa Check No. 5097
Legal	\$ 543.54	La Mesa Check No. 5138
Variance Application	\$ 350.00	Dona Ana County (LRG Check No. 2238)
Variance Application	\$ 150.00	Dona Ana County (LRG Check No. 2385)
Total	\$ 5,049.16	
Construction Observation & Special Services		
Construction Observation (Est.)	\$ 70,000.00	T&M (\$50,000 in contract)
Hydrogeologist (Est.)	\$ 25,000.00	T&M (\$15,000 in contract)
Subtotal	\$ 95,000.00	
NMGRT (7.5625%)	\$ 7,184.38	
Total	\$ 102,184.38	
O&M Manual		TBD
Training/Project Performance		TBD
Contingencies (5% Construction)	\$ 75,000.00	
Total	\$ 75,000.00	
Construction		
Construction	\$ 1,414,696.61	Burn Construction Bid
Subtotal	\$ 1,414,696.61	
Construction Taxes (6.375%)	\$ 90,186.91	
Total Construction	\$ 1,504,883.52	
Loan Refinance		
RIP Loan	\$ 57,187.95	Remaining Balance as of 03/02/2012
Grand Total	\$ 1,900,197.10	
USDA RD Grant	\$ 1,569,346.00	
USDA RD Loan	\$ 471,000.00	
Total Funding Available	\$ 2,040,346.00	
Remaining Funding	\$ 140,148.90	

** \$1,414,696.61 * 7.7% = \$108,931.64

Lower Rio Grande PWWA
La Mesa Well No. 3
Funded by: USDA RD
Bid Tabulation - March 1, 2012

BID SCHEDULE			Engineer's Estimate		Burn Construction Company		Caliper Construction Inc.		Highland Enterprises		Bradbury Stamm		Morrow Enterprises Inc.		AUI Inc.		Smithco Construction		
Item No.	Item Description	UNIT	EST. QTY.	UNIT PRICE	AMOUNT	UNIT PRICE	AMOUNT	UNIT PRICE	AMOUNT	UNIT PRICE	AMOUNT	UNIT PRICE	AMOUNT	UNIT PRICE	AMOUNT	UNIT PRICE	AMOUNT		
1	Mobilization & demobilization, preparation of SWPPP and NOI per Dona Ana County Standards.	LS	1	\$ 100,000.00	\$ 100,000.00	\$ 21,659.61	\$ 21,659.61	\$ 51,000.00	\$ 51,000.00	\$ 8,122.00	\$ 8,122.00	\$ 94,500.00	\$ 94,500.00	\$ 25,000.00	\$ 25,000.00	\$ 150,000.00	\$ 150,000.00	\$ 75,000.00	\$ 75,000.00
2	8" PVC Waterline, including material, labor, trenching, compaction and all appurtenances, complete in place.	LF	5,300	\$ 25.00	\$ 132,500.00	\$ 16.60	\$ 87,980.00	\$ 15.50	\$ 82,150.00	\$ 18.70	\$ 99,110.00	\$ 26.00	\$ 137,800.00	\$ 21.00	\$ 111,300.00	\$ 18.00	\$ 95,400.00	\$ 18.50	\$ 98,050.00
3	6" Gate Valve, with valve box, including all material, labor and appurtenances, complete in place.	EA	1	\$ 1,300.00	\$ 1,300.00	\$ 1,324.30	\$ 1,324.30	\$ 892.00	\$ 892.00	\$ 1,235.00	\$ 1,235.00	\$ 1,100.00	\$ 1,100.00	\$ 1,500.00	\$ 1,500.00	\$ 1,371.00	\$ 1,371.00	\$ 1,350.00	\$ 1,350.00
4	1" Combination Air/Vac Valve Station, including manhole & butterfly valve, material, labor and all related appurtenances, complete in place.	EA	1	\$ 1,600.00	\$ 1,600.00	\$ 3,223.90	\$ 3,223.90	\$ 3,921.00	\$ 3,921.00	\$ 1,062.00	\$ 1,062.00	\$ 1,300.00	\$ 1,300.00	\$ 2,200.00	\$ 2,200.00	\$ 2,909.00	\$ 2,909.00	\$ 3,500.00	\$ 3,500.00
5	Tie to existing PVC Waterline, including material, labor and all appurtenances, complete in place.	EA	1	\$ 1,500.00	\$ 1,500.00	\$ 1,534.88	\$ 1,534.88	\$ 196.00	\$ 196.00	\$ 845.00	\$ 845.00	\$ 500.00	\$ 500.00	\$ 1,250.00	\$ 1,250.00	\$ 1,134.00	\$ 1,134.00	\$ 1,500.00	\$ 1,500.00
6	3/4-inch water service, including all material, labor and appurtenances, average length of service is 50 feet, complete in place.	EA	3	\$ 700.00	\$ 2,100.00	\$ 789.92	\$ 2,369.76	\$ 902.00	\$ 2,706.00	\$ 880.00	\$ 2,640.00	\$ 1,200.00	\$ 3,600.00	\$ 1,500.00	\$ 4,500.00	\$ 1,764.00	\$ 5,292.00	\$ 1,050.00	\$ 3,150.00
7	STA. 62+00 EBID drain crossing, complete in place iron carrier pipe, spacers and all related appurtenances, complete in place.	LS	1	\$ 3,000.00	\$ 3,000.00	\$ 3,193.13	\$ 3,193.13	\$ 12,960.00	\$ 12,960.00	\$ 4,807.00	\$ 4,807.00	\$ 3,500.00	\$ 3,500.00	\$ 14,450.00	\$ 14,450.00	\$ 11,902.00	\$ 11,902.00	\$ 12,500.00	\$ 12,500.00
8	Mobilization/Demobilization, mobilize and demobilize all well drilling equipment.	LS	1	\$ 30,000.00	\$ 30,000.00	\$ 39,592.10	\$ 39,592.10	\$ 34,580.00	\$ 34,580.00	\$ 39,891.00	\$ 39,891.00	\$ 35,000.00	\$ 35,000.00	\$ 34,000.00	\$ 34,000.00	\$ 35,909.00	\$ 35,909.00	\$ 70,000.00	\$ 70,000.00
9	Drilling Well, drill well pilot hole, including all	LF	800	\$ 40.00	\$ 32,000.00	\$ 59.89	\$ 47,912.00	\$ 57.20	\$ 45,760.00	\$ 66.00	\$ 52,800.00	\$ 55.00	\$ 44,000.00	\$ 56.00	\$ 44,800.00	\$ 59.50	\$ 47,600.00	\$ 70.00	\$ 56,000.00
10	Geophysical Log, run geophysical log of well, including all equipment and labor, complete in place.	LS	1	\$ 10,000.00	\$ 10,000.00	\$ 9,790.05	\$ 9,790.05	\$ 9,350.00	\$ 9,350.00	\$ 10,787.00	\$ 10,787.00	\$ 9,000.00	\$ 9,000.00	\$ 9,104.00	\$ 9,104.00	\$ 9,709.00	\$ 9,709.00	\$ 17,500.00	\$ 17,500.00
11	Water Samples, Pilot hole water samples at 280', 430', 580' and 740' depth's, including all equipment and labor.	EA	4	\$ 2,000.00	\$ 8,000.00	\$ 3,282.54	\$ 13,130.16	\$ 3,135.00	\$ 12,540.00	\$ 3,617.00	\$ 14,468.00	\$ 3,000.00	\$ 12,000.00	\$ 3,053.00	\$ 12,212.00	\$ 3,255.00	\$ 13,020.00	\$ 20,000.00	\$ 80,000.00
12	Reaming Well Pilot Hole, ream pilot hole to 24" diameter, including all equipment and labor, complete in place.	LF	200	\$ 70.00	\$ 14,000.00	\$ 99.05	\$ 19,810.00	\$ 94.60	\$ 18,920.00	\$ 110.00	\$ 22,000.00	\$ 100.00	\$ 20,000.00	\$ 93.00	\$ 18,600.00	\$ 98.20	\$ 19,640.00	\$ 150.00	\$ 30,000.00
13	Reaming Well Pilot Hole, ream pilot hole to 18" diameter, including all equipment and labor, complete in place.	LF	550	\$ 70.00	\$ 38,500.00	\$ 84.08	\$ 46,244.00	\$ 80.30	\$ 44,165.00	\$ 93.00	\$ 51,150.00	\$ 90.00	\$ 49,500.00	\$ 79.00	\$ 43,450.00	\$ 83.40	\$ 45,870.00	\$ 90.00	\$ 49,500.00
14	Well Plumbness and Alignment Test, perform well plumbness and alignment test, including all equipment and labor.	LS	1	\$ 2,000.00	\$ 2,000.00	\$ 5,182.96	\$ 5,182.96	\$ 4,950.00	\$ 4,950.00	\$ 5,711.00	\$ 5,711.00	\$ 5,000.00	\$ 5,000.00	\$ 4,820.00	\$ 4,820.00	\$ 5,140.00	\$ 5,140.00	\$ 4,250.00	\$ 4,250.00
15	Surface Casing, place well surface casing 20" diameter, grouted and backfilled, including all material and labor, complete in place.	LF	200	\$ 100.00	\$ 20,000.00	\$ 120.93	\$ 24,186.00	\$ 115.50	\$ 23,100.00	\$ 133.00	\$ 26,600.00	\$ 130.00	\$ 26,000.00	\$ 112.00	\$ 22,400.00	\$ 119.90	\$ 23,980.00	\$ 125.00	\$ 25,000.00
16	Blank Casing, place well blank casing 14" diameter, including all material and labor, complete in place.	LF	600	\$ 45.00	\$ 27,000.00	\$ 114.02	\$ 68,412.00	\$ 108.90	\$ 65,340.00	\$ 126.00	\$ 75,600.00	\$ 120.00	\$ 72,000.00	\$ 106.00	\$ 63,600.00	\$ 113.10	\$ 67,860.00	\$ 75.00	\$ 45,000.00
17	Well Screen, place well screen 14" diameter, including all material and labor, complete in place.	LF	150	\$ 140.00	\$ 21,000.00	\$ 282.18	\$ 42,327.00	\$ 269.50	\$ 40,425.00	\$ 311.00	\$ 46,650.00	\$ 300.00	\$ 45,000.00	\$ 263.00	\$ 39,450.00	\$ 279.80	\$ 41,970.00	\$ 200.00	\$ 30,000.00
18	Dissimilar Metal Connectors, provide and install 14" dissimilar metal connectors, including all material and labor, complete in place.	EA	5	\$ 1,200.00	\$ 6,000.00	\$ 1,727.66	\$ 8,638.30	\$ 1,650.00	\$ 8,250.00	\$ 1,904.00	\$ 9,520.00	\$ 1,600.00	\$ 8,000.00	\$ 1,606.00	\$ 8,030.00	\$ 1,713.00	\$ 8,565.00	\$ 5,000.00	\$ 25,000.00
19	Well Gravel Pack, place well gravel pack, including all material and labor, complete in place.	CY	50	\$ 230.00	\$ 11,500.00	\$ 1,243.91	\$ 62,195.50	\$ 1,188.00	\$ 59,400.00	\$ 1,371.00	\$ 68,550.00	\$ 1,200.00	\$ 60,000.00	\$ 1,157.00	\$ 57,850.00	\$ 1,233.70	\$ 61,685.00	\$ 465.00	\$ 23,250.00
20	Well Development Set Up, set up for development of well, including all equipment and labor, complete in	LS	1	\$ 8,000.00	\$ 8,000.00	\$ 9,098.99	\$ 9,098.99	\$ 8,690.00	\$ 8,690.00	\$ 10,025.00	\$ 10,025.00	\$ 10,000.00	\$ 10,000.00	\$ 8,461.00	\$ 8,461.00	\$ 9,024.00	\$ 9,024.00	\$ 16,500.00	\$ 16,500.00
21	Well Development, perform well development, including all labor, complete in place.	HRS	40	\$ 400.00	\$ 16,000.00	\$ 575.89	\$ 23,035.60	\$ 550.00	\$ 22,000.00	\$ 635.00	\$ 25,400.00	\$ 600.00	\$ 24,000.00	\$ 536.00	\$ 21,440.00	\$ 572.00	\$ 22,880.00	\$ 700.00	\$ 28,000.00
22	Test Pumping Set Up, prepare for test pumping of well, including all equipment and labor, complete in place.	LS	1	\$ 12,000.00	\$ 12,000.00	\$ 13,700.30	\$ 13,700.30	\$ 13,085.00	\$ 13,085.00	\$ 15,095.00	\$ 15,095.00	\$ 15,000.00	\$ 15,000.00	\$ 12,800.00	\$ 12,800.00	\$ 13,588.00	\$ 13,588.00	\$ 16,500.00	\$ 16,500.00
23	Test Pumping, perform test pumping of well, complete in place.	HRS	32	\$ 275.00	\$ 8,800.00	\$ 287.94	\$ 9,214.08	\$ 275.00	\$ 8,800.00	\$ 317.00	\$ 10,144.00	\$ 300.00	\$ 9,600.00	\$ 268.00	\$ 8,576.00	\$ 286.00	\$ 9,152.00	\$ 250.00	\$ 8,000.00
24	Well Sterilization, perform well sterilization, including all material and labor, complete in place.	LS	1	\$ 1,500.00	\$ 1,500.00	\$ 2,879.42	\$ 2,879.42	\$ 2,750.00	\$ 2,750.00	\$ 3,173.00	\$ 3,173.00	\$ 3,000.00	\$ 3,000.00	\$ 2,678.00	\$ 2,678.00	\$ 2,855.00	\$ 2,855.00	\$ 1,650.00	\$ 1,650.00
25	Temporary Discharge Line, furnish temporary discharge line for disposal of test pump water from well, including all material and labor, complete in place.	LS	1	\$ 2,000.00	\$ 2,000.00	\$ 1,727.66	\$ 1,727.66	\$ 1,650.00	\$ 1,650.00	\$ 1,904.00	\$ 1,904.00	\$ 1,900.00	\$ 1,900.00	\$ 1,607.00	\$ 1,607.00	\$ 1,713.00	\$ 1,713.00	\$ 1,500.00	\$ 1,500.00

Lower Rio Grande PWWA
La Mesa Well No. 3
Funded by: USDA RD
Bid Tabulation - March 1, 2012

BID SCHEDULE				Engineer's Estimate		Burn Construction Company		Caliper Construction Inc.		Highland Enterprises		Bradbury Stamm		Morrow Enterprises Inc.		AUI Inc.		Smitheo Construction	
Item No.	Item Description	UNIT	EST. QTY.	UNIT PRICE	AMOUNT	UNIT PRICE	AMOUNT	UNIT PRICE	AMOUNT	UNIT PRICE	AMOUNT	UNIT PRICE	AMOUNT	UNIT PRICE	AMOUNT	UNIT PRICE	AMOUNT	UNIT PRICE	AMOUNT
26	New Well Pump, furnish and install new submersible well pump at well site, including all discharge column pipe, discharge elbow, and pump power cable, including all material, labor and all appurtenances, complete in place.	LS	1	\$ 40,000.00	\$ 40,000.00	\$ 34,380.34	\$ 34,380.34	\$ 32,835.00	\$ 32,835.00	\$ 37,880.00	\$ 37,880.00	\$ 36,000.00	\$ 36,000.00	\$ 32,000.00	\$ 32,000.00	\$ 34,098.00	\$ 34,098.00	\$ 26,500.00	\$ 26,500.00
27	Well House, including process piping & related appurtenances and equipment including all work and items in Division 2 through 16, inclusive as shown on the Contract Drawings, within 5' outside of building perimeter, complete in place, excluding Section 11234, Disinfection Equipment, and SCADA Equipment.	LS	1	\$ 200,000.00	\$ 200,000.00	\$ 180,271.58	\$ 180,271.58	\$ 212,500.00	\$ 212,500.00	\$ 229,430.00	\$ 229,430.00	\$ 235,000.00	\$ 235,000.00	\$ 250,000.00	\$ 250,000.00	\$ 216,513.00	\$ 216,513.00	\$ 200,000.00	\$ 200,000.00
28	Water Storage Tank - 150,000 gallons (net) welded steel, with Foundation & Impressed Current Cathodic Protection, including all piping, painting/coating, including NACE Certified Coating Inspector and all related appurtenances within 7' of foundation, complete in place.	LS	1	\$ 200,000.00	\$ 200,000.00	\$ 259,955.87	\$ 259,955.87	\$ 229,075.00	\$ 229,075.00	\$ 264,850.00	\$ 264,850.00	\$ 240,000.00	\$ 240,000.00	\$ 225,000.00	\$ 225,000.00	\$ 224,692.00	\$ 224,692.00	\$ 250,000.00	\$ 250,000.00
29	Well and Tank Site Work, construction staking and fencing, including all work (Division 2 through 16) within site property limits, excluding water tank and well house, complete in place.	LS	1	\$ 50,000.00	\$ 50,000.00	\$ 87,494.77	\$ 87,494.77	\$ 127,400.00	\$ 127,400.00	\$ 117,437.00	\$ 117,437.00	\$ 100,000.00	\$ 100,000.00	\$ 180,000.00	\$ 180,000.00	\$ 107,487.00	\$ 107,487.00	\$ 125,000.00	\$ 125,000.00
30	Access Road, water tank and well site access road surfacing from Well No. 2 Site to Well No. 3 Site, as shown on drawings, including 6" subgrade preparation and 4" of base course, complete in place.	LF	1350	\$ 12.50	\$ 16,875.00	\$ 12.64	\$ 17,064.00	\$ 23.32	\$ 31,482.00	\$ 4.65	\$ 6,277.50	\$ 22.00	\$ 29,700.00	\$ 15.00	\$ 20,250.00	\$ 21.00	\$ 28,350.00	\$ 22.50	\$ 30,375.00
31	Disinfection Equipment, furnish and install new disinfection equipment per Specification Section 11234, complete in place.	LS	1	\$ 15,000.00	\$ 15,000.00	\$ 17,728.68	\$ 17,728.68	\$ 28,650.00	\$ 28,650.00	\$ 19,797.00	\$ 19,797.00	\$ 23,000.00	\$ 23,000.00	\$ 20,000.00	\$ 20,000.00	\$ 31,043.00	\$ 31,043.00	\$ 23,500.00	\$ 23,500.00
32	Site Electrical, all electrical work inside of fence, complete in place.	LS	1	\$ 150,000.00	\$ 150,000.00	\$ 118,472.23	\$ 118,472.23	\$ 102,850.00	\$ 102,850.00	\$ 92,101.00	\$ 92,101.00	\$ 65,000.00	\$ 65,000.00	\$ 121,000.00	\$ 121,000.00	\$ 100,568.00	\$ 100,568.00	\$ 115,000.00	\$ 115,000.00
33	Electric Service, allowance for well three phase power, coordinate with El Paso Electric Company, complete in place.	Allow	1	\$ 50,000.00	\$ 50,000.00	\$ 50,000.00	\$ 50,000.00	\$ 50,000.00	\$ 50,000.00	\$ 50,000.00	\$ 50,000.00	\$ 50,000.00	\$ 50,000.00	\$ 50,000.00	\$ 50,000.00	\$ 50,000.00	\$ 50,000.00	\$ 50,000.00	\$ 50,000.00
34	Water Laboratory Analysis Allowance	Allow	1	\$ 3,000.00	\$ 3,000.00	\$ 3,000.00	\$ 3,000.00	\$ 3,000.00	\$ 3,000.00	\$ 3,000.00	\$ 3,000.00	\$ 3,000.00	\$ 3,000.00	\$ 3,000.00	\$ 3,000.00	\$ 3,000.00	\$ 3,000.00	\$ 3,000.00	\$ 3,000.00
35	Utility Line Relocation Allowance	Allow	1	\$ 5,000.00	\$ 5,000.00	\$ 5,000.00	\$ 5,000.00	\$ 5,000.00	\$ 5,000.00	\$ 5,000.00	\$ 5,000.00	\$ 5,000.00	\$ 5,000.00	\$ 5,000.00	\$ 5,000.00	\$ 5,000.00	\$ 5,000.00	\$ 5,000.00	\$ 5,000.00
36	Inspection Testing Allowance	Allow	1	\$ 15,000.00	\$ 15,000.00	\$ 15,000.00	\$ 15,000.00	\$ 15,000.00	\$ 15,000.00	\$ 15,000.00	\$ 15,000.00	\$ 15,000.00	\$ 15,000.00	\$ 15,000.00	\$ 15,000.00	\$ 15,000.00	\$ 15,000.00	\$ 15,000.00	\$ 15,000.00
TOTAL					\$ 1,255,175.00		\$ 1,356,729.17		\$ 1,415,372.00		\$ 1,448,061.50		\$ 1,493,000.00		\$ 1,495,328.00		\$ 1,523,919.00		\$ 1,566,075.00
Additive Alternate																			
1	Back Up Power Generator, as shown in Plans & Specifications. Including all related site work, concrete pad, electrical work and related appurtenances, complete in place	LS	1	\$ 80,000.00	\$ 80,000.00	\$ 57,967.44	\$ 57,967.44	\$ 56,100.00	\$ 56,100.00	\$ 51,000.00	\$ 51,000.00	\$ 42,000.00	\$ 42,000.00	\$ 54,000.00	\$ 54,000.00	\$ 44,021.00	\$ 44,021.00	\$ 65,000.00	\$ 65,000.00
TOTAL					\$ 80,000.00		\$ 57,967.44		\$ 56,100.00		\$ 51,000.00		\$ 42,000.00		\$ 54,000.00		\$ 44,021.00		\$ 65,000.00
TOTAL BID AMOUNT (exclusive of NMGR)					\$ 1,335,175.00		\$ 1,414,696.61		\$ 1,471,472.00		\$ 1,499,061.50		\$ 1,535,000.00		\$ 1,549,328.00		\$ 1,567,940.00		\$ 1,631,075.00
TOTAL BID AMOUNT PLUS NMGR (6.2500%)					\$ 1,418,623.44		\$ 1,503,115.15		\$ 1,563,439.00		\$ 1,592,752.84		\$ 1,630,937.50		\$ 1,646,161.00		\$ 1,665,936.25		\$ 1,733,017.19

I hereby certify that the above figures are the same as those submitted in the Bid Proposal, except as otherwise amended in accordance with the Contract Documents.

Wyatt B. Kartchner, P.E.

3/5/12
Date

Corrected Math Error